



Thermoelectric temperature sensor Ex d (Ex t, Ex i) to thermowell DIN with connecting screw-joint on adapter without converter or with converter type series 330 type 335

PRODUCT MANUAL

FOR DESIGNS WITH CONVERTER A MANUAL IS ENCLOSED TO THE RELEVANT CONVERTER
 FOR DESIGNS WITH CONVERTER AND DISPLAY A MANUAL IS ENCLOSED TO THE RELEVANT CONVERTER AND DISPLAY

APPLICATION

- For exact remote measurement of temperature of steady and running liquids (gases and fluids), for which the properties of the thermowell of the sensor selected by the customer are suitable; measurement may be realized up to pressure determined by thermowell resistance
- For environment with explosive gaseous atmosphere according to EN 60079-10-1 and explosive atmospheres with combustible dust according to EN 60079-10-2
 - o Sensor may be installed into the thermowell located in zone 1, 2, 21 and 22
- In a set with control or diagnostic systems for process monitoring
- In design with converter for transfer of thermoelectric sensor signal to unified output signal 4 to 20 mA or digital signal (converter with HART protocol)
- In design with display to display the value of the measured value
- For the environment, where mechanical resistance is required pursuant to EN 60068-2-6 (class AH2) and seismic capability of the electrical equipment of the safety system of the nuclear power stations pursuant to IEC 980 (MVZ level SL-2)

The sensors are rated products pursuant to the Directive 2014/34/EU, 2014/30/EU of the European Parliament and the Council and EU Declaration of Conformity **EU -335000** is issued for them.

DESCRIPTION

The sensor consists of a replaceable measuring insert with flange and ceramic terminal board or installed two-wire converter (insulated or non-insulated, even in design Ex ia) and protective armature consisting of a head and an adapter with a screw-joint for the connection of the sensor into the thermowell selected by the customer. The head with measuring insert and gland form a fixed closure Ex d. It is provided with a lid, which can be screwed, and a cable gland for the connecting wiring. The cable gland (pursuant to the required diameter of the cable) forms optional accessories to the sensor. The terminal board (of the converter) of the sensor is accessible after removing the lid of the head, which is fixed, after being tightened, with a pin against spontaneous releasing. The sensor is provided with an external clamp on the head for the connection of the grounding wire or wires for mutual interconnection.

The sensor with converter is supplied from an external source. The installed converter is pre-set to the required range at the sensor manufacturer.

To measure temperature, a defined change of thermoelectric voltage of the sensor in dependence on the change of temperature of the measured environment is used.

TECHNICAL DATA

The sensor design is based on DIN 43772. The sensor is designed pursuant to EN 61140 as an electric equipment of protection class III for the application in networks with category of overvoltage in installation II and pollution grade 2 pursuant to EN 61010-1; the follow-up (evaluation) device shall comply with Article 6.3 of the said standard.

Measuring range:

| Min. length of adapter L_n [mm] | Thermocouple type | Measuring range [°C] |
|-----------------------------------|-------------------|----------------------|
| 125 | J | -200 to 800 *) |
| | K | -200 až 1150 *) |
| 65 | J, K | -200 to 250 |

*) The upper limit of the measuring range is limited by resistance of the material of the thermowell; however, it may not exceed 450°C.

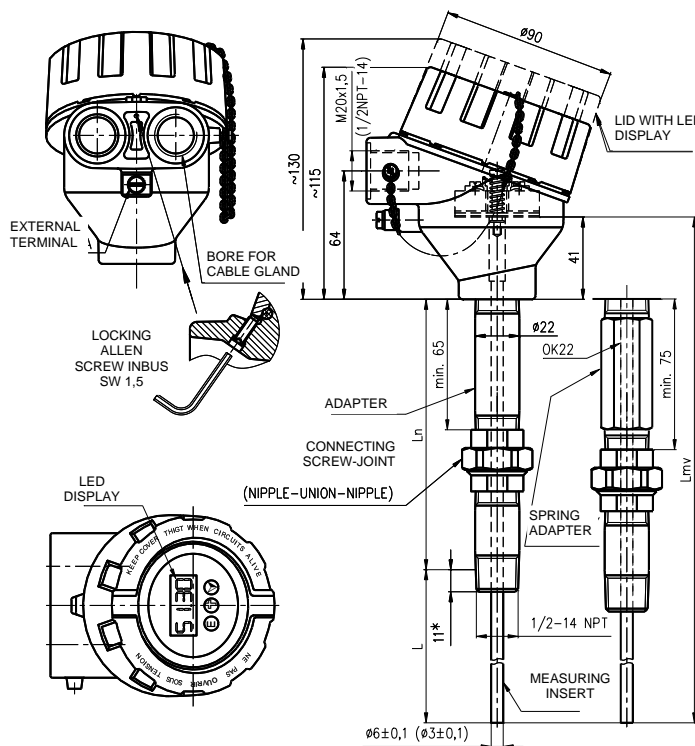

- L nominal length
- L_n length of adapter
- L_{mv} length of measuring insert (does not apply to spring adapter)
- 11* standard length of screwing

If it is ensured in a suitable way that the surface temperature of the part of the sensor located in the dangerous area does not exceed the temperature of the required temperature class (T1...T6), the upper limit of the range of measurement may also be higher (max. 1150°C for thermocouple **K**, max. 800°C for thermocouple **J**). Example of installation - refer to Figure 5.

Measuring range of the sensor with converter is established by the range of the selected converter.

Design for explosive atmospheres:

Fixed closure pursuant to EN IEC 60079-0 and EN 60079-1,

Ex II 2 G Ex db IIC T6...T1 Gb

(Meaning of designation - refer to figure 6)

Dust-tight closure pursuant to EN IEC 60079-0 and EN 60079-31:

Ex II 2 D Ex tb IIC T=T media Db

(Meaning of designation - refer to figure 6)

Intrinsically safe pursuant to EN IEC 60079-0 and EN 60079-11:

Ex II 1 G Ex ia IIC T5/T6 Ga

(Meaning of designation - see figure 7)

$P_i = 500 \text{ mW}$ $T_6 (-60^\circ\text{C} \leq T_a \leq 68^\circ\text{C})$

Intrinsically safe circuit parameters:

only for thermocouple "K" and "J", with measuring insert $\varnothing 6$

$U_i = 60 \text{ V}$ $U_o = 100 \text{ mV}$

$I_i = 100 \text{ mA}$ $I_o = 50 \text{ mA}$

$P_i = 500 \text{ mW}$ $P_o = 25 \text{ mW}$

$C_i = 850 \text{ pF/m}$

$L_i = 16 \text{ } \mu\text{H/m}$



WARNING

The device must be installed in a housing that meets the degree of protection against intrusion of at least IP 20.



The casing of the measuring insert is not separated from the inner intrinsically safe circuit according to the standard EN 60079-11. This information must be taken into account during installation.

Intrinsically safe version with converter:
according to built-in converter

Electric strength pursuant to EN 61010-1, Article 6.8.3:
500 V eff (only measuring insert without converter or design with insulated converter)

Electric insulation resistance pursuant to EN 61515, Article 5.3.2.4:
min. 1000 MΩ, at ambient temperature 20±15°C and max. 80% relative humidity, test voltage 500 V DC

Power supply of converter:
DC 24 V from source SELV, e.g. INAP 16 and INAP 901

Other data of converter: refer to the enclosed manual
Display: LED display to loop 4-20mA
other data refer to enclosed manual

Ingress protection pursuant to EN 60529
IP 68, 1m, 30 min

Operation position:
discretionary; the outlet shall not be situated upwards

Type of operation: continuous

Sensor weight:
with adapter 135 mm 0.93 kg

Applied materials:

| | | |
|-------------------------------------|------------------------------|--------------------------------------------------------------|
| Stem tube of measuring insert | for thermocouple of type "J" | Steel 1.4541 |
| | for thermocouple of type "K" | INCONEL 600 |
| Adapter with connecting screw-joint | | Steel 1.4541 |
| Head | | Aluminium alloy painted with polyester paint Steel 1.4401 |
| Sealing of lid of head and gland | | Oil-resistant rubber |
| Head terminals of terminal board | | Brass with Ni surface |
| Connecting items of sensor | | Stainless steel |

OPERATION CONDITIONS

The environment is defined by the group of parameters and their severity grades IE 36 pursuant to EN 60721-3-3 and the following operation conditions.

Ambient temperature for head and outlet of the sensor according to the type of heads used:

- -50°C ≤ Ta ≤ 75°C for the heads of Al Alloy (XD- AD;XD-ADH)
- -50°C ≤ Ta ≤ 70°C for stainless steel heads (XD-SD)
- -40°C ≤ Ta ≤ 75°C for heads (XD-I80C; XD-I80Cwin)
- for design with converter (and display) pursuant to the type of converter (and display) (refer to the enclosed converter and display manual)

Maximum surface temperature of the sensor:
it complies with maximum temperature of the measured medium

Maximum surface temperature for equipment operating in the environment with a threat of explosion of gases, steam and mist pursuant to EN 60079-0 and temperature class of the sensor are determined in dependency on the temperature of measured medium pursuant to the following table:

| Temperature class | Maximum surface temperature | Maximum temperature of measured medium |
|-------------------|-----------------------------|----------------------------------------|
| T6 | 85°C | 80°C |
| T5 | 100°C | 95°C |
| T4 | 135°C | 130°C |
| T3 | 200°C | 195°C |
| T2 | 300°C | 290°C |
| T1 | 450°C | 440°C |

For temperatures of the measured medium greater than the limit for temperature class T1, the maximum surface temperature Tx is determined from the maximum temperature of the measured Tm media and the safety addition of 10 ° C.
Tx = Tm+10 ° C.

Maximum permitted surface temperature for the equipment operating in the environment with a threat of explosion of dust pursuant to EN 61241-14:

- a) Temperature limitation due to occurrence of stirred dust:
 $T_{max} = 2/3 T_{cl}$
where T_{cl} is the temperature of ignition of stirred dust
- b) Temperature limitation due to occurrence of layers of dust to 5mm thickness: $T_{max} = T_{5mm} - 75 ° C$
where T_{5mm} is the temperature of ignition of dust layer 5mm thick
- c) Dust layers over 5 mm – refer to EN 61241-14

Maximum permitted surface temperature is defined by the lower value of the values specified above.

Intrinsically safe measuring inserts can be used in intrinsically safe circuits of group II electrical equipment.



WARNING



The user shall guarantee that the maximum surface temperature of any part of the sensor does not exceed the temperatures of ignition of any gas, steam or dust, which can occur, due to external thermal effects.

Relative ambient humidity:

- 10 to 100 % with condensation, with upper limit of water content 29 g H₂O/kg of dry air
- For design with converter pursuant to type of converter (refer to enclosed converter manual)
- For design with converter and display (refer to enclosed converter and display manual)

Atmospheric pressure: 70 to 106 kPa

Vibrations:

| Sensor | with converter | | without converter | |
|--------------------------------------------|----------------|----------|-------------------|----------|
| | 130, 140, 170 | 220, 260 | 130, 140, 170 | 200, 260 |
| Nominal length L [mm] | | | | |
| Frequency range [Hz] | 10 to 500 | | | |
| Drift amplitude [mm] | 0.2 | 0.15 | 0.5 | 0.2 |
| Acceleration amplitude [ms ⁻²] | 29.4 | 19.6 | 68.7 | 39.2 |

Maximum speed of flow of liquids:

pursuant to parameters of thermowell used by the customer

METROLOGICAL DATA

Sensing probe: measuring thermocouple J (Fe-CuNi) or K (NiCr-NiAl) pursuant to EN 60584-1, Ø 6 or Ø 3 mm, tolerance class 2 or 1, single with insulated measuring end or double with independent measuring end

Output signal

- of analogue converter (linear with thermoelectric voltage):
4 to 20 mA
- of programmable converter (linear with measured temperature):
4 to 20 mA (+ digital for HART protocol)

Calibration depth of immersion of the measuring insert of the sensor

- for temperature points within range -70 to 250°C:
200 mm (min. 160 mm)
- for temperature points above 250°C:
300 mm (min. 260 mm)

The distance of flange of the measuring insert from the level of medium in the calibration bath shall be at least 40 mm at temperatures to 250°C and min. 70 mm at temperatures above 250°C.

Temperature response time pursuant to EN 60751 in whirling water (characteristic value):

- without thermowell (separate measuring insert)
 $\tau_{0.5}$ 5.5 s
- with thermowells pursuant to DIN 43772, shape 4 (L = 100, 140))
 $\tau_{0.5}$ 85 s
 $\tau_{0.9}$ 250 s
- with thermowells pursuant to DIN 43772, shape 4 (L = 200, 260))
 $\tau_{0.5}$ 53 s
 $\tau_{0.9}$ 115 s

DESIGNATION :

Data of head label

- Trademark of the manufacturer
- Made in Czech Republic
- Type of thermoelectric sensor / tolerance class
- Measuring range or set-up converter range
- Product ordering number
- Ingress protection
- Serial number
- Output signal 4 to 20 mA (design with converter)

- Ambient temperature
- Designation of non-explosiveness:
 - ⊕ II 2 G Ex db IIC T6...T1 Gb
 - ⊕ II 2 D Ex tb IIC T=T media Db
 - ⊕ II 1 G Ex ia IIC T5/T6 Ga
- EU-Type Examination Certificate number
- Designation of non-explosiveness and EU-Type Examination Certificate number (for design with converter Ex ia)
- CE mark 1026

Data on label of measuring insert

- Trade mark
- Sensor type / tolerance class
- Serial number

Data on converter label

- Trademark
- Sensor type
- Pre-set temperature range
- Designation of non-explosiveness and EU-Type Examination Certificate number for design with converter Ex ia
- CE mark with identification number of the notified person (for design with converter Ex ia)

Data on display

- Trademark
- CE mark

DELIVERY

Unless agreed otherwise with the customer, each delivery includes

- Delivery note
- Sensor pursuant to the purchase order
- Allen key 1.5mm
- Separately ordered accessories; pursuant to the catalogue of, type 991:
 - o Suitable thermowells and nipples
 - o Suitable cable gland. An instruction sheet is delivered with each cable gland
- Optional accessories to the sensor with programmable converter
 - o Configuration (parameterization) programme pursuant to the required converter
 - o Communication modem (for serial port RS 232C) pursuant to the required converter
- Accompanying technical documentation in Czech
 - o Product manual
 - o Product quality and completeness certificate, which also serves as the warranty certificate
 - o EU Declaration of Conformity

If it is established in the purchase contract or agreed otherwise, the following documentation can be also delivered with the product

- Calibration sheet (for uncertified calibrated design)
- EU Declaration of Conformity

CERTIFICATION

- Non-explosiveness Ex ia, EU-Type Examination Certificate pursuant to the Directive 2014/34/EU FTZÚ 08 ATEX 0199X as amended
- Non-explosiveness Ex ia, EU-Type Examination Certificate pursuant to the Directive 2014/34/EU FTZÚ 21 ATEX 0007X
- Non-explosiveness Ex ia, EU-Type Examination Certificate pursuant to the 2014/34/EU (pursuant to the type of the converter and display)

CALIBRATION

It is realized pursuant to TPM 3322-94 and in compliance with EN 584, usually in three temperature points evenly distributed within the operation range of the sensor or in the points according to the requirement of the customer. Calibration sheets with measured data are issued for calibrated sensors.

RELIABILITY

Indicators of reliability in operation conditions and ambient conditions specified herein

- Medium time of operation between failures 96 000 hours (inf. value)

Expected service life 10 years

PACKING

Both sensors and accessories are delivered in a packing ensuring resistance to the impact of thermal effects and mechanical effects pursuant to controlled packing regulations.

TRANSPORT

The sensors may be transported on conditions corresponding to the set of combinations of classes IE 21 pursuant to EN IEC 60721-3-2 (i.e. by airplanes and trucks, in premises that are ventilated and protected against atmospheric conditions).

STORAGE

The products may be stored on conditions corresponding to the set of combinations of classes IE 12 pursuant to EN IEC 60721-3-1, but with ambient temperature from -20 to 70 °C (i.e. in places without control of temperature and humidity, with danger of occurrence of condensation, dropping water and formation of ice, without a special threat of an attack with biological agents, with vibrations of small significance and not situated close to sources of dust and sand).

ORDERING TEMPERATURE SENSORS

The purchase order shall specify

- Name
- Product ordering number
- Ex ia design is ordered using codes JIX, or DUX according to Table 1
- Additional requirements for sensor design pursuant to Table 2
- Request for other documentation pursuant to Table 2
- Measuring range
- If calibration is required and in what temperature points
- If the delivery of a nipple pursuant to the type 991 is required for the sensor as accessories
- If the delivery of gland for output cable pursuant to the type 991 is required for the sensor as accessories
- If optional accessories to the sensor with programmable converter is required
- Request for other documentation according to Article DELIVERY
- Other (special) requirements
- Number of pieces

Behind the ordering number specified pursuant to the above mentioned table, the customer shall identify the required range of measured temperature (i.e. lower and upper temperature limits in °C) and, as the case may be, other non-standard required parameters for converter configuration (e.g. indication of sensor tripping, dampening, required designation - tagging etc.).

PURCHASE ORDER EXAMPLE

Standard design:

Thermoelectric temperature sensor Ex d (Ex t) to thermowell DIN without converter
335 410 511 K2/JI/Q4
Calibration points 250, 350 and 450°C
Range -70 to 450°C
6 pcs

Special requirement:

Thermoelectric temperature sensor Ex d (Ex t) to thermowell DIN with converter
335 910 511 J2/HCF
nominal length L = 380 mm, range 0 to 300°C
6 pcs

ORDERING ACCESSORIES

The purchase order shall specify:

- Name
- Ordering number
- Number of pieces

EXAMPLE OF PURCHASE ORDER

Standard design:

1. Welding thermowell pursuant to DIN shape 4 991 DIN 407544
20 pcs

- 2. Nipple
991 NVD4 D26 72
6 pcs
- 3. Cable gland
991 VM 612
6 pcs

TABLE 1 - DESIGN OF TEMPERATURE SENSORS Ex d (Ex t, Ex i) TO THERMOWELL DIN - TYPE 335

| SPECIFICATIONS | | | | | ORDERING NUMBER | | | | | | | | | | | | | | | | | |
|---------------------------------------------------------------|------------------------------------------------|------------------------------------------------------------------------------|--------------------------------------------------------------------------------------|-------------------------------------------------|-----------------|---|----------|---|---|---|---|---|---|---|---|---------|------|--|--|--|--|--|
| | | | | | 335 | x | x | x | x | x | x | x | x | x | x | /xxxxxx | /xxx | | | | | |
| Nominal length L [mm] | 110 | Length of adapter L _n [mm] | 125 (135) *** | Length of measuring insert L _{mv} [mm] | 275 | 1 | 1 (4) | | | | | | | | | | | | | | | |
| | 140 | | 135 | | 315 | 2 | | | | | | | | | | | | | | | | |
| | 170 | | 125 (135) *** | | 335 | 3 | | | | | | | | | | | | | | | | |
| | 200 | | 135 | | 375 | 4 | | | | | | | | | | | | | | | | |
| | 260 | | | | 435 | 5 | | | | | | | | | | | | | | | | |
| | 410 | | | | 585 | 6 | | | | | | | | | | | | | | | | |
| | Other (min. 75)* | | | | | | | 9 | | | | | | | | | | | | | | |
| Nominal length L [mm] | 110 | Length of adapter L _n [mm] | 65 (75) *** (without connecting screw-joint) | Length of measuring insert L _{mv} [mm] | 215 | 1 | 2 (3) | | | | | | | | | | | | | | | |
| | 140 | | | | 245 | 2 | | | | | | | | | | | | | | | | |
| | 170 | | | | 275 | 3 | | | | | | | | | | | | | | | | |
| | 200 | | | | 305 | 4 | | | | | | | | | | | | | | | | |
| | 260 | | | | 365 | 5 | | | | | | | | | | | | | | | | |
| | 410 | | | | 515 | 6 | | | | | | | | | | | | | | | | |
| | Other (min. 75)* | | | | | | | 9 | | | | | | | | | | | | | | |
| Length of adapter L _n [mm] | Adapter | 135mm (125mm) | | | 1 | | | | | | | | | | | | | | | | | |
| | | 65 mm (without connecting screw-joint) max. measuring range [°C] -200 to 250 | | | 2 | | | | | | | | | | | | | | | | | |
| | | Other (min. 65 mm) *)** | | | 9 | | | | | | | | | | | | | | | | | |
| | Spring adapter | 75 mm (without connecting screw-joint) max. measuring range [°C] -200 to 250 | | | 3 | | | | | | | | | | | | | | | | | |
| | | 135 | | | 4 | | | | | | | | | | | | | | | | | |
| Other (min. 65 mm) *)** | | | | | 9 | | | | | | | | | | | | | | | | | |
| Thermowell material | without thermowell | | | | 0 | | | | | | | | | | | | | | | | | |
| Connecting thread | 1/2-14 NPT | | | | 5 | | | | | | | | | | | | | | | | | |
| | Other *) | | | | 9 | | | | | | | | | | | | | | | | | |
| Sensor head with thread for gland Ex d (Ex t) | Aluminium alloy painted with blue epoxy colour | | M20x1.5 | | 1 | | | | | | | | | | | | | | | | | |
| | Corrosion-resistant steel 1.4401 | | 1/2-14NPT | | 2 | | | | | | | | | | | | | | | | | |
| | | | M20x1.5 | | 3 | | | | | | | | | | | | | | | | | |
| | | | 1/2-14NPT | | 4 | | | | | | | | | | | | | | | | | |
| Tube of measuring insert [mm] | Ø6 ± 0,1 | | | | | | | | | | 1 | | | | | | | | | | | |
| Thermocouple | K | | | | | | | | | | | K | | | | | | | | | | |
| | J | | | | | | | | | | | J | | | | | | | | | | |
| | Other *) | | | | | | | | | | | 9 | | | | | | | | | | |
| Accuracy class | 1 *) | | | | | | | | | | | | | | | 1 | | | | | | |
| | 2 | | | | | | | | | | | | | | | 2 | | | | | | |
| Design of measuring ends of thermocouple pursuant to figure 1 | Single thermocouple, insulated end | | | | | | | | | | | | | | | /JI | | | | | | |
| | Double thermocouple, independent end | | | | | | | | | | | | | | | /DU | | | | | | |
| | Single thermocouple, insulated end | | only for TC "K" a "J", length of measuring insert L _{mv} 100 – 3025 [mm] | | | | | | | | | | | | | | /JIX | | | | | |
| | Double thermocouple, independent end | | | | | | | | | | | | | | | | /DUX | | | | | |

TABLE 1 - DESIGN OF TEMPERATURE SENSORS Ex d (Ex t, Ex i) TO THERMOWELL DIN - TYPE 335 (continuation)

| SPECIFICATIONS | | | | | ORDERING NUMBER | | | | | | | | | | | | | | | |
|---------------------------------------------------------------------------------------------------------------------------------|-----------------------------------------------------------------------|------------------|---------------------|-------|-----------------|--------------------|---|---|---|---|---|---|---|---|---------|------|--|-----|---------|----------|
| | | | | | 335 | x | x | x | x | x | x | x | x | x | /xxxxxx | /xxx | | | | |
| Converter (design of thermocouple measuring ends: single thermocouple, isolated end) | Converter type | | Galvanic separation | Ex ia | NFC | Range [°C] | | | | | | | | | | | | | | |
| | Programmable linear output signal with temperature | TH 200 | • | | | Programmable range | | | | | | | | | | | | | /TH200 | |
| | | TH 200-ex | • | • | | | | | | | | | | | | | | | | /TH200X |
| | | MINIPAQ-HLP | | | | | | | | | | | | | | | | | | /MINIPAQ |
| | | APAQ C130 | | | • | | | | | | | | | | | | | | | /C130 |
| | | IPAQ C202 | | | | | | | | | | | | | | | | | | /C202 |
| | | IPAQ C330 | • | | • | | | | | | | | | | | | | | | /C330 |
| | | IPAQ C330X | • | • | • | | | | | | | | | | | | | | | /C330X |
| | | IPAQ C520 | • | | | | | | | | | | | | | | | | | /C520 |
| | | IPAQ C520S ****) | • | | | | | | | | | | | | | | | | | /C520S |
| | | IPAQ C520X | • | | • | | | | | | | | | | | | | | | /C520X |
| | IPAQ C520XS *****) | • | | • | | | | | | | | | | | | | | | /C520XS | |
| | IPAQ C530 | • | | • | | | | | | | | | | | | | | | /C530 | |
| | IPAQ C530X | • | • | • | | | | | | | | | | | | | | | /C530X | |
| | Programmable with HART protocol linear output signal with temperature | TH 300 | • | | | | | | | | | | | | | | | | | /TH300 |
| | | TH 300-ex | • | • | | | | | | | | | | | | | | | | /TH300X |
| | | 248 HA NA | • | | | | | | | | | | | | | | | | | /248HANA |
| | | 248 HA I1 | • | | • | | | | | | | | | | | | | | | /248HA1X |
| | | 644 HA NA | • | | | | | | | | | | | | | | | | | /644HANA |
| | | 644 HA I1 | • | | • | | | | | | | | | | | | | | | /644HA1X |
| Other *) | | | | | | | | | | | | | | | | | | | /99 | |
| Without converter (for converter installation by the customer) | | | | | | | | | | | | | | | | | | /00 | | |
| LED display to loop 4-20 mA (not possible with head from corrosion resistant steel) (only with converter APAQ-HRF, MINIPAQ-HLP) | | | | | | LPI-02 | | | | | | | | | | | | /LD | | |

Standard design

- *) Only as a special requirement after an agreement with the manufacturer
- ***) In case of adapter length below 125 mm (minimum 65 mm), the temperature range is decreased to -70 to 250 °C.
- ****) In case of spring adapter length below 135 mm (minimum 75 mm), the temperature range is decreased to -70 to 250 °C.
- *****) The value in brackets applies to the spring adapter
- *****) Lengths of measuring inserts for spring extension are not listed
- *****) Functional safety SIL2

TABLE 2 – ADDITIONAL REQUIREMENT FOR DESIGN OF TEMPERATURE SENSORS Ex d (Ex t, Ex i) TO THERMOWELL, TYPE 335

| SPECIFICATIONS | | | CODE |
|------------------------------------------------------------------------|------------------------------|---------------------------|------|
| CALIBRATION | NUMBER OF CALIBRATION POINTS | CALIBRATION RANGE | |
| Calibration by TPM 3342-94, define calibration points | 3 | 0 to 800 °C | /Q4 |
| | 3 | 0 to 1100 °C | /Q42 |
| | Other | 0 to 1100 °C | /Q9 |
| REQUIREMENT FOR OTHER DOCUMENTATION | | USE | |
| EU Declaration of Conformity | | for design with converter | /EU |
| Copy of EU-Type Examination Certificate acc to the 2014/34/EU (ATEX) | | for Ex ia design | /Exi |
| Declaration of Conformity with purchase order 2.1 pursuant to EN 10204 | | | /2.1 |

Specify the code behind ordering number. Define calibration points for codes Q4, Q42 a Q9.

TABLE 3 - OVERVIEW OF DESIGNS AND ORDERING OF WELDING THERMOWELLS PURSUANT TO DIN, SHAPE 4 (4F) PURSUANT TO DIN 43772, TYPE 991 (ordered separately)

| SPECIFICATIONS | | | | | | ORDERING NUMBER | | | | | | | | | | |
|----------------------------------------------|-------------------------------------|--------------------|---------------------|------------------------------------|-----|-----------------|-----|---|---|---|---|---|---|---|---|---|
| | | | | | | 991 | DIN | x | x | x | x | x | x | | | |
| Shape 4 | pursuant to DIN 43772 | Without flange | | PN 250 | | | | 4 | 0 | | | | | | | |
| | | With flange *) **) | | | | | | 4 | F | | | | | | | |
| Internal bore [mm] | | | | ø 7 | | | | | | 7 | | | | | | |
| Internal thread / internal Ø thermowell [mm] | | | | 1/2 - 14 NPT/ Ø 26 | | | | | | | 5 | | | | | |
| Cone welding thermowell | Nominal length of thermowell L [mm] | L1 [mm] | 110 | L2 [mm] | 65 | 105 | | | | | | | | | 1 | |
| | | | 140 | | 65 | 135 | | | | | | | 2 | | | |
| | | | 170 | | 133 | 165 | | | | | | | 3 | | | |
| | | | 200 | | 65 | 195 | | | | | | | 4 | | | |
| | | | 200 | | 125 | 195 | | | | | | | 5 | | | |
| | | | 260 | | 125 | 255 | | | | | | | 6 | | | |
| | | | 410 | | 275 | 405 | | | | | | | 7 | | | |
| | | | Other (max. 410) *) | | | | | | | | | | 9 | | | |
| | Material of thermowell II | 1.7335 ***) | | Maximum operation temperature [°C] | 550 | | | | | | | | | | | 1 |
| | | 1.7380 ***) | | | 580 | | | | | | | | | | | 2 |
| 1.4541 *****) | | 580 | | | | | | | | | | | | 3 | | |
| 1.4571 *****) | | 400 | | | | | | | | | | | | 4 | | |
| 1.5415 *) ***) | | 530 | | | | | | | | | | | | 5 | | |
| 1.4903 *) *****) | | 620 | | | | | | | | | | | | 6 | | |
| A105, C22.8 or 1.0460 (P250GH) *) *****) | | 425 | | | | | | | | | | | | 7 | | |
| 1.4404 *) *****) | | 550 | | | | | | | | | | | | 8 | | |
| Other *) | | | | | | | | | | | | | 9 | | | |

- *) As a special requirement after an agreement with the manufacturer
- ***) Design of flange (shape, PN, DN and material) pursuant to the requirement of the customer
- *****) Thermowells of these materials cannot be used for zone 0

****) Surface treatment of thermowells: preservation with grease – oil
 ****) For zone 0, it is necessary to use a thermowell from corrosion resistant steel (pursuant to EN 60079-26)
 ****) thermowells of these materials are suitable for contact with food

TABLE 4 – ACCESSORIES - OVERVIEW OF DESIGNS RECOMMENDED NIPPLES FOR WELDING THERMOWELLS, TYPE 991 (order separately)

| SPECIFICATION | | | | | ORDERING NUMBER | | | | | |
|-----------------------------------------------------------------------------------|--------------------|---------------------------------------|------|------------------------------------|-----------------|-----|---|-----|----|----|
| | | | | | 991 | xxx | x | xxx | xx | |
| Nipple pursuant to DIN 43772 for welding thermowell shape 4 pursuant to DIN 43772 | Direct nipple | | | | | NVD | 4 | | | |
| | Internal bore [mm] | | Ø 26 | | | | | D26 | | |
| | Material | 15 128.5 **) | | maximum operation temperature [°C] | 550 | | | | | 51 |
| | | 1.4541 | | | 550 | | | | | 72 |
| | | 1.5415 *) **) | | | 530 | | | | | 50 |
| | | 1.4903 *) **) | | | 620 | | | | | 71 |
| | | A105, C22.8 or 1.0460 (P250GH) *) **) | | | 425 | | | | | 20 |
| | | 1.4404 *) **) | | | 550 | | | | | 73 |
| | | Other *) **) | | | | | | | | 99 |

*) upon a special requirement after an agreement with the manufacturer
 **) surface treatment of thermowells: preservation with grease – oil

TABLE 5 – ACCESSORIES - OVERVIEW OF DESIGNS RECOMMENDED SCREW-IN THERMOWELLS SHAPE 7 PURSUANT TO DIN 43772, TYPE 991 (order separately)

| SPECIFICATION | | | | | ORDERING NUMBER | | | | | | | | | | |
|---------------------------------------|-------------------------------------|-----------------------------|---------------|---------|------------------------------------|-----|---|---|---|---|---|---|---|---|---|
| | | | | | 991 | DIN | K | x | x | x | x | x | x | | |
| Cone screw-in thermowell | Shape 7 pursuant to DIN 43772 | | PN 250 | | | | K | | | | | | | | |
| | Internal bore [mm] | | Ø 7 | | | | | 7 | | | | | | | |
| | External fixing thread | ½ - 14 NPT | | | | | | | 5 | | | | | | |
| | | ¾ - 14 NPT | | | | | | | 7 | | | | | | |
| | | 1 - 11,5 NPT | | | | | | | 8 | | | | | | |
| | | other *) **) | | | | | | | 9 | | | | | | |
| | Internal thread for sensor | | ½ - 14 NPT | | | | | | 5 | | | | | | |
| | Nominal length of thermowell L [mm] | 110 | | L1 [mm] | 105 | | | | | | | | 1 | | |
| | | 140 | | | 135 | | | | | | | | | 2 | |
| | | 170 | | | 165 | | | | | | | | | 3 | |
| | | 200 | | | 195 | | | | | | | | | 4 | |
| | | 260 *) **) | | | 255 | | | | | | | | | 6 | |
| | | 410 *) **) | | | 405 | | | | | | | | | 7 | |
| | | Other (maximum 1200) *) **) | | | | | | | | | | | | 9 | |
| | | Material of thermowell | 1.7335 *) **) | | maximum operation temperature [°C] | 550 | | | | | | | | | 1 |
| | 1.7380 *) **) | | 580 | | | | | | | | | | | 2 | |
| | 1.4541 ****) | | 580 | | | | | | | | | | | 3 | |
| | 1.4571 ****) | | 400 | | | | | | | | | | | 4 | |
| | 1.5415 *) **) | | 530 | | | | | | | | | | | 5 | |
| | 1.4903 *) **) | | 620 | | | | | | | | | | | 6 | |
| A105, C22.8 or 1.0460 (P250GH) *) **) | | | 425 | | | | | | | | | | | 7 | |
| 1.4404 *) **) | | | 550 | | | | | | | | | | | 8 | |
| Other *) **) | | | | | | | | | | | | 9 | | | |

*) upon a special requirement after an agreement with the manufacturer
 **) Thermowells of these materials cannot be used for zone 0
 **) surface treatment of thermowells: preservation with grease – oil
 ***) For zone 0, thermowell from corrosion resistant steel shall be used (pursuant to (pursuant to EN 60079-26)
 ****) thermowells of these materials are suitable for contact with food

TABLE 6 – ACCESSORIES - OVERVIEW OF DESIGNS RECOMMENDED NIPPLES FOR SCREW-IN THERMOWELLS, TYPE 991 (order separately)

| SPECIFICATION | | | | | ORDERING NUMBER | | | | | |
|-------------------------------------------------------------------|-----------------------|----------------------|--|------------------------------------|------------------|-----|---|-----|-----|----|
| | | | | | 991 | xxx | x | xxx | xx | |
| Nipple for screw-in thermowells pursuant to DIN 43772 shape 6 a 7 | Direct nipple | | | | | NVP | | | | |
| | Oblique (chamfer 45°) | | | | | NVS | | | | |
| | Internal thread | ¾ - 14 NPT | | PN | 160 | | | 4 | N34 | |
| | | Other *) **) | | | | | | | 999 | |
| | Material | 1.0308 or 1.0122 **) | | maximum operation temperature [°C] | 300 (only PN 40) | | | | N34 | 13 |
| | | 15 128.5 **) | | | 550 | | | | G34 | 51 |
| | | 1.4541 | | | 550 | | | | | 72 |
| Other *) **) | | | | | | | | 99 | | |

*) upon a special requirement after an agreement with the manufacturer
 **) surface treatment of thermowells: preservation with grease – oil

TABLE 7 - OVERVIEW OF DESIGNS AND ORDERING OF CABLE GLANDS Ex d (Ex t) BRASS – TYPE 991

| SPECIFICATION | | | | | | | Ordering number | | | |
|-------------------------|--------|-------------------------------|------------|-----------|--------|----------------------|------------------|---------|-----|-----|
| | | | | | | | 991 | XX | XXX | |
| Gland Ex d (Ex t) brass | | Cable clamp (clamping module) | | | Thread | Torque of gland body | For cable Ø [mm] | | | |
| Size | Wrench | | Size | Dimension | | | | | | |
| | A | B | | C | Ds | | | | | |
| No. 4 | OK 17 | OK 24 | No. 4 | 5 | 20 | M20x1.5 | 30 - 35 Nm | 4,5-8.5 | VM | 458 |
| No. 5 | OK 19 | | No. 5 | 5 | 22 | | | 7-11 | VM | 711 |
| No. 6 | OK 24 | | No. 6 | 6 | 27.5 | | | 10-16 | VM | 016 |
| No. 4 | OK 17 | | 1/2-14 NPT | No. 4 | 5 | 20 | 25 - 30 Nm | 4,5-8.5 | VK | 458 |
| No. 5 | OK 19 | | | No. 5 | 5 | 22 | | 7-11 | VK | 711 |
| No. 6 | OK 24 | | | No. 6 | 6 | 27.5 | | 10-15.5 | VK | 015 |

INSTALLATION AND CONNECTION

SENSOR INSTALLATION

Install the sensors by screwing into the relevant thermowell screwed into the nipple on the piping (technological equipment) or welded into the piping wall. During the installation, torque of 40 Nm is recommended.

With respect to maintaining metrological properties and the longest possible service life, it is not recommended to install the sensors in places with high turbulence of the medium, which is caused e.g. by a rapid transition from a small diameter of the piping to a larger one (when failing to comply with the required shape and dimensions of diffuser behind the flow meter), etc. Recommended distance of the temperature sensor from the installation flange of the flow meter is min. 1 m.



WARNING

The temperature sensor may be installed to the thermowell located in the zone 1 (1) or zone 2 (22)



Distance of the fixed closure EX d IIC from close structures or between the suspensions shall be at least 40 mm.

The temperature sensor with a paint finish must be installed in an explosive atmosphere with dust so as to avoid the occurrence of creep discharges

EXAMPLES OF INSTALLATION OF THERMOWELLS DIN

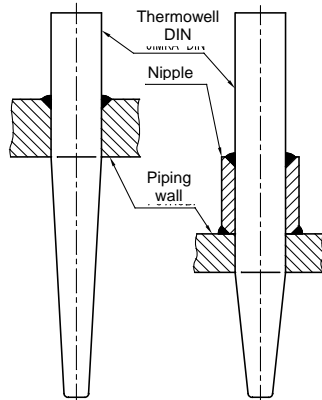

INSTALLATION OF CABLE GLAND

To secure the fixed closure (dust-tight closure), only the certified cable gland Ex d IIC (Ex tb IIC) with coverage IP 68 shall be used (see accessories 991 or another similar gland). For temperature sensors with converter, a barrier cable gland must be used in zone 1 of the IIC gas gauge, or an Ex ia converter. The gland shall be tightened in the sensor head in the prescribed way.

Torque of outlet body:

- a) for outlet with thread 1/2 - 14NPT 25 – 30Nm
- b) for outlet with thread M20x1.5 30 – 35Nm

Installation of the cable in the outlet, its sealing and securing against pull-out shall be realized pursuant to the instruction sheet of the outlet supplier.



WARNING

Do not use other sealing rings in the outlet than the original ones delivered by the manufacturer. Do not change artificially the outer diameter of the cable e.g. by winding it around with electrical insulating tapes.

ELECTRICAL CONNECTION

The electrical connection may be only realized by qualified workers.

The sensor installation in conditions with explosive gaseous atmosphere or flammable dust shall comply with the requirements of EN 60079-14.

The terminal board of the sensor (converter) is accessible after the removal of the cover of the head.

Connect the evaluation devices to the sensor with a cable with double insulation; internal wires with Cu core (sensor with converter) or compensation wiring (sensor without converter) 0.5 to 1.5 mm². Sensors without converter connect with unarmoured shielded compensation or double insulated thermocouple wiring with cross section 0.5 to 1.5 mm² and outer diameter according to cable gland.

Seal the cable in the outlet by prescribed tightening of the closing nut pursuant to instruction sheet of the outlet. Then secure it with clamp against pull-out.



WARNING

Do not use independent wires without jacket for electrical connection. The cable must be circular and compact, the filler or shell must be extruded and the filler material, if used, must be non-absorbent. The length of the connecting cable must be at least min. 3 m. Temperature resistance of the cable shall comply with the ambient temperature!



The cable insulation shall have chemical and mechanical resistances in compliance with the conditions, in which the cable will be installed. It is recommended supporting the cable along its length between the sensor and the follow-up device. Shielding may be only grounded (earthed) in one point. In the environment with interfering signals, use shielded cable in the power supply circuit. The cable should not be placed together with power cables.

In case of the sensor with HART protocol converter, the maximum length of wiring is defined by the arrangement of wires of the connecting cable. The total length of wiring may be up to 1500 m. It requires a twisted two-wire with shared shielding with the diameter of the cross section min. 0.5 mm². HART communicator is connected to the supply loop of the converter pursuant to figure 3. To achieve reliable communication, resistor 250 shall be introduced in the circuit of the output loop.



WARNING

Programmable converter may not be connected to a computer or a HART communicator if the converter is located in explosive environment.



The surface temperature of the converter must not exceed the maximum surface temperature for a given temperature class.

For the installations in dangerous areas, mutual connection is required (bringing to the same potential). To achieve it, clamps on the sensor head can be used.

The sensor need not be connected to the system of mutual connection independently if it is installed firmly and has metal interconnection with the structural parts of piping, which is connected to the system of mutual connection.

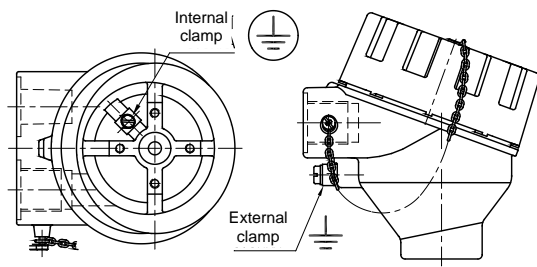
SENSOR HEAD WITH CLAMPS**Maximum cross-section of wire for connection to external and internal clamps:**

Internal clamp: stranded wire 1.5 mm², full wire 2.5 mm²

External clamp: stranded wire 4.0 mm², full wire 6.0 mm²

If stranded wires are used for the interconnection, they shall be protected against fraying with pressing hollow.

CLOSING HEAD OF FIXED CLOSURE Ex d

After electrical connection of the sensor, the lid of the head shall be fully tightened by hand, then released slightly to ensure matching with the closest groove against the securing pit and fixed by this screw against releasing. If the lid of the sensor is not tightened and secured by the above mentioned screw, the sensor does not comply with the requirements of fixed closure Ex d.

**WARNING:**

Electric supply of the sensor may not be connected before closing the fixed closure!

**SENSOR INSTALLATION WITHOUT CONVERTER AND SENSOR WITH CONVERTER Ex ia TO ZONE 0 (20)****WARNING:**

The user is responsible for ensuring that during operation in zone 0 is between the sensor head from an aluminium alloy and other equipment preclude any risk of ignition due to impact and friction.



The sensor without converter can be used, in case of the installation pursuant to EN 60079-11, Art. 5.7 in the intrinsically safe circuit Ex ia according to EN 60079-25), as a simple equipment. For simple equipment, the maximum temperature can be determined from the value of the P0 of the follower and the temperature class is determined.

Sensor with converter Ex ia can be used while adhering to the Ex ia parameters of the converter shall be complied with pursuant to the enclosed converter manual.

In intrinsically safe circuits, only insulated cables that are capable of withstanding an electrical strength test with a voltage equal to twice the voltage in the intrinsically safe circuit or 500 V eff (DC 750 V) must be used, with a larger value being taken.

When installing intrinsically safe circuits, including cables, do not exceed the maximum allowable inductance, capacity or ratio LiR and surface temperature. Permissible values are determined from the documentation of the connecting device or label. Place follow-up equipment out of the danger area. An intrinsically safe source approved for supplying intrinsically safe devices in accordance with EN 60079-11 must always be used.

The shield of the intrinsically safe circuit cable must be grounded in the same place as the intrinsically safe circuit, the connection must be outside the dangerous area.

If the intrinsically safe circuit is isolated from the ground, the shield must be connected in one place to the protective interconnection system. This can be using the terminals on the sensor head.

COMMISSIONING

After the sensor installation, including the fixed closure, and connection of the follow-up (evaluation) device to the supply voltage (and the settlement period of the converter), the equipment is prepared for operation.

**WARNING**

After installation must be require initial inspection equipment and installations according to EN 60079-17

**OPERATION AND MAINTENANCE**

The sensor does not require any operation; maintenance and follow-up regular periodic revision or permanent supervision of expert staff are performed pursuant to EN 60079-17.

**WARNING**

Any intervention into the sensor and its structure will result in a change of properties and can result in an explosion!

**SENSOR UNINSTALLATION****WARNING**

Warning: Temperature sensor is in design Ex and must be disconnected from the supply source before opening the lid of the head and releasing the cable gland in the explosive environment!



Release the securing screw of the lid by ALLEN key 1.5 mm (a part of accessories). The terminal board of the sensor (converter) is accessible after unscrewing the lid of the head.

Measuring insert of the sensor can be replaced and is uninstalled from the head after disconnecting the cable by releasing two screws.

Before a complete uninstallation of the sensor, the wire for mutual interconnection shall be released from the external clamp on the sensor.

Disconnect the connecting cable from the terminal board, then release it from the clamp on the gland and from closing nut of the gland. Unscrew the sensor from the thermowell; torque for releasing is approx. 40 Nm. While releasing the screw-joint of the sensor, the thermowell may never be released.

REPAIRS

The sensors shall be repaired by the manufacturer. They shall be sent for repair in the original or equal package without accessories.

SPARE PARTS

Spare parts shall be delivered by the manufacturer.

Relevant measuring inserts can be ordered pursuant to the following table (the table applies only to the version without a spring adapter):

EXAMPLE OF PURCHASE ORDER OF MEASURING INSERT

Thermoelectric measuring insert without converter

MV330 /375/ 1K2/JI

6 pcs

To order the certified measuring inserts, specify the code according to Table 2 – Additional requirements – behind the ordering number.

| SPECIFICATIONS | | ORDERING NUMBER | | | | | |
|--------------------------------------------------------------------------------------------|--------------------------------------|-----------------|--------------------|---|---|---|------------|
| | | MV330 | /xxx/ | x | x | x | /xxxx |
| Length of measuring insert [mm] | | | Pursuant to tab. 1 | | | | |
| ø measuring insert [mm] | 6 ± 0,1 | | | 1 | | | |
| | 3 ± 0,1 | | | 3 | | | |
| Sensing probe | Thermocouple K | | | | K | | |
| | Thermocouple J | | | | J | | |
| Accuracy class | 1 | | | | | 1 | |
| | 2 | | | | | 2 | |
| Connection of the terminal board and design of measuring ends of thermocouple or converter | Single thermocouple, insulated end | | | 1 | | | /JI |
| | Double thermocouple, independent end | | | | | | /DU |
| | | | | 1 | | | |
| Converter pursuant to tab. 1 | | | | | | | /converter |

*) Ex ia design (only with measuring insert ø 6, length of measuring insert L_{mv} 100 – 3025 [mm])

The measuring inserts are marked according to Article DESIGNATION. Designation is completed with the ordering number.

Each delivery includes

- Delivery note
- Measuring insert pursuant to the purchase order
- Optional accessories to the measuring insert with a programmable converter
 - o Configuration program according to the required converter
 - o Communication modem (for serial port RS 232C) according to the required converter
- Accompanying technical documentation in Czech
 - o Product manual
 - o Product quality and completeness certificate, which also serves as the warranty certificate
 - o EU Declaration of Conformity (for Ex ia design)

If it is established in the purchase contract or agreed otherwise, the following documentation can be also delivered with the product

- Calibration sheet (for calibrated design)
- EU Declaration of Conformity (for design with converter)
- Copy of EU-Type Examination Certificate pursuant to the Directive No 2014/34/EU for Ex ia design

WARRANTY

The warranty period is 24 months from the receiving of the product by the customer, unless established otherwise in the contract. Rejection of defects shall be enforced in writing at the manufacturer within the warranty period. The rejecting side shall identify the product name, ordering and manufacturing numbers, date of issue and number of the delivery note, clear description of the occurring defect and the subject of the claim. If the rejecting side is invited to send the device for repair, it shall do so in the original package of the manufacturer and/or in another package ensuring safe transport.

The warranty shall not apply to defects caused by unauthorized intervention into the device, its forced mechanical damage or failure to comply with operation conditions of the product and the product manual.

DISABLING AND LIQUIDATION

The product and its package do not include any parts that could impact the environment.

Products that are withdrawn from operation, including their packages (with the exception of products marked as electrical equipment for the purposes of return withdrawal and separate salvage of electrical waste), may be disposed of to sorted or unsorted waste pursuant to the type of waste.

The manufacturer realizes free return withdrawal of marked electrical equipment (from 13.8.2005) from the consumer and points out the danger connected with their illegal disposal. The package of the sensor can be recycled completely. Metal parts of the products are recycled, non-recyclable plastic materials and electrical waste shall be disposed of in accordance with applicable legislation.

FIGURE 1 - DESIGN OF MEASURING ENDS OF JACKETED THERMOCOUPLES (SCHEMATIC ILLUSTRATION)

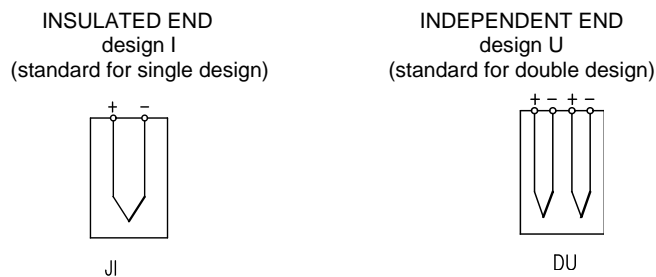
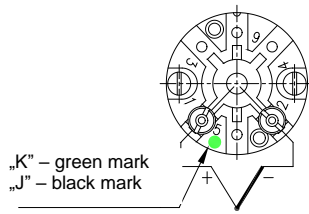

FIGURE 2 - SCHEME OF CONNECTION OF TEMPERATURE SENSORS

SCHEME OF CONNECTION WITHOUT CONVERTER

with single thermocouple



with double thermocouple

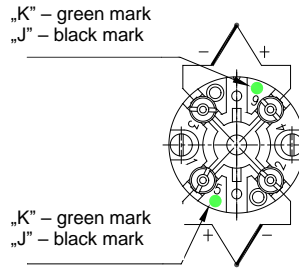

SCHEME OF CONNECTION WITH CONVERTER AND DISPLAY

with converter

with converter
with HART protocol

with converter Ex ia

with converter Ex ia
with HART protocol

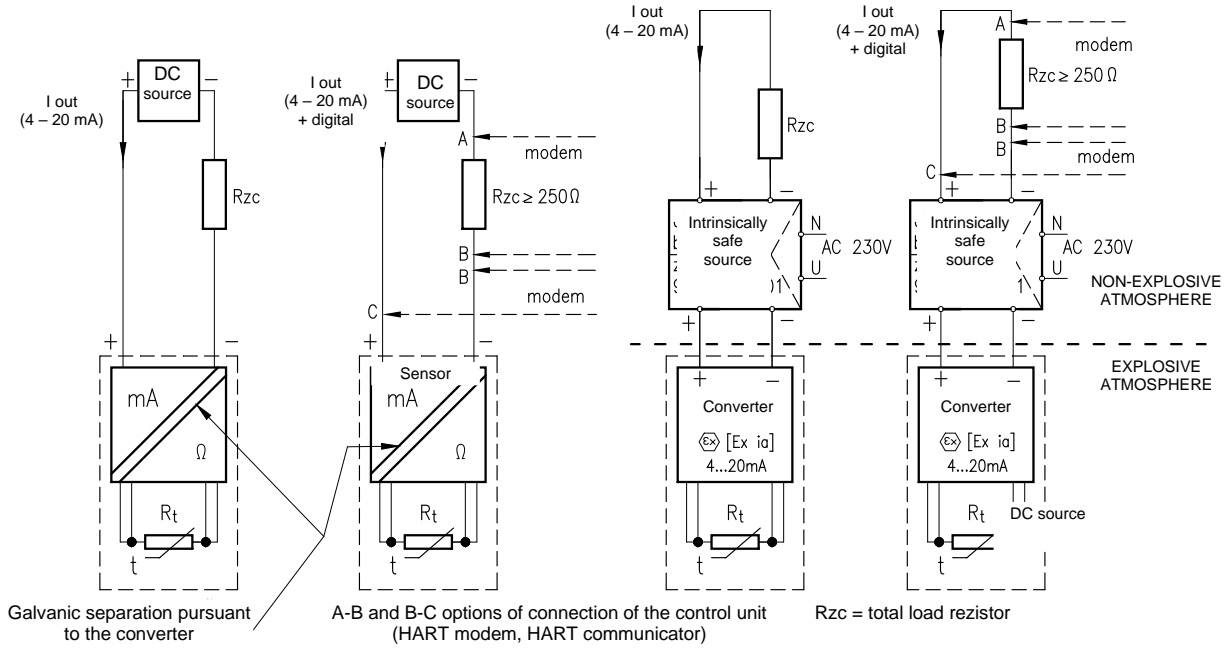

FIGURE 3 - EXAMPLE OF OPERATION CONNECTION OF TEMPERATURE SENSOR WITH CONVERTER IN LOOP 4 - 20 mA

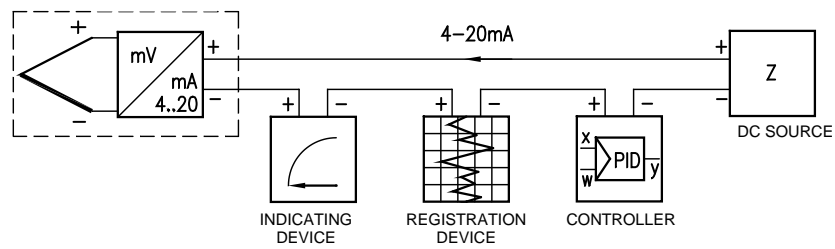

FIGURE 4 – EXAMPLE OF INSTALLATION OF TEMPERATURE SENSORS Ex d TO THERMOWELL DIN
 (for cases when a higher upper limit of the measurement range is required than the required temperature class)

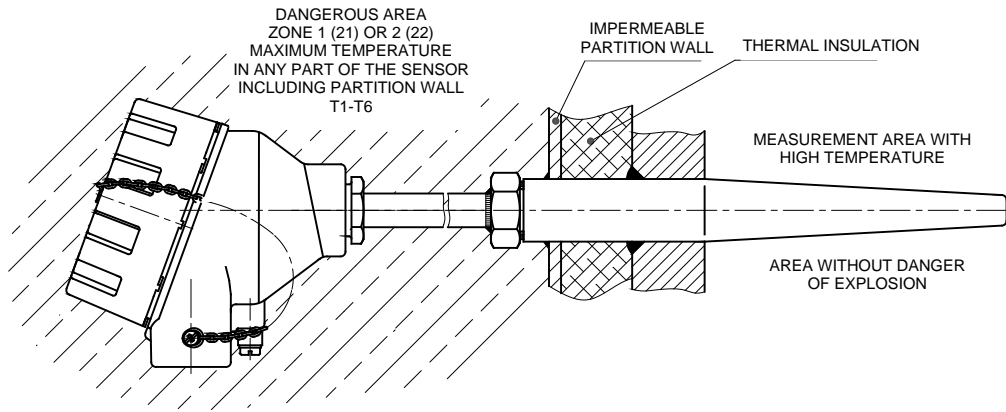

FIGURE 5 – THERMOWELL FOR TEMPERATURE SENSOR Ex d FOR ZONE 0 (pursuant to EN 60079-26)

The thermowell, which is used in the function of the partition wall between the zones 1 or 2 and zone 0, shall be made of corrosion-resistant metal and with wall thickness $t \geq 1$ mm.

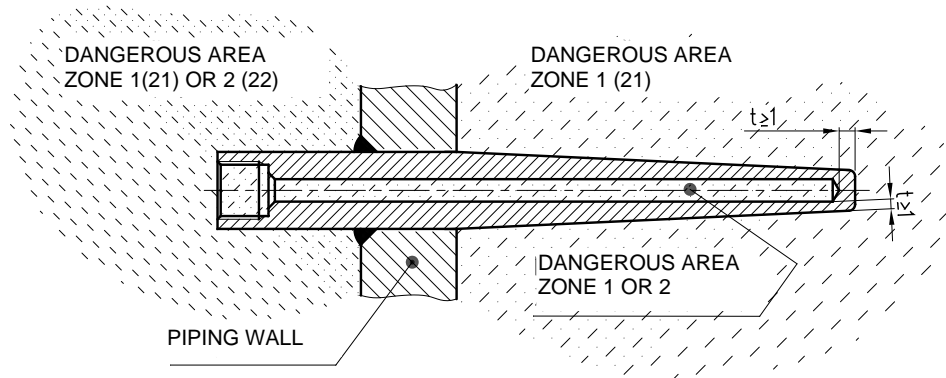

FIGURE 6 – MARK OF NON-EXPLOSIVENESS

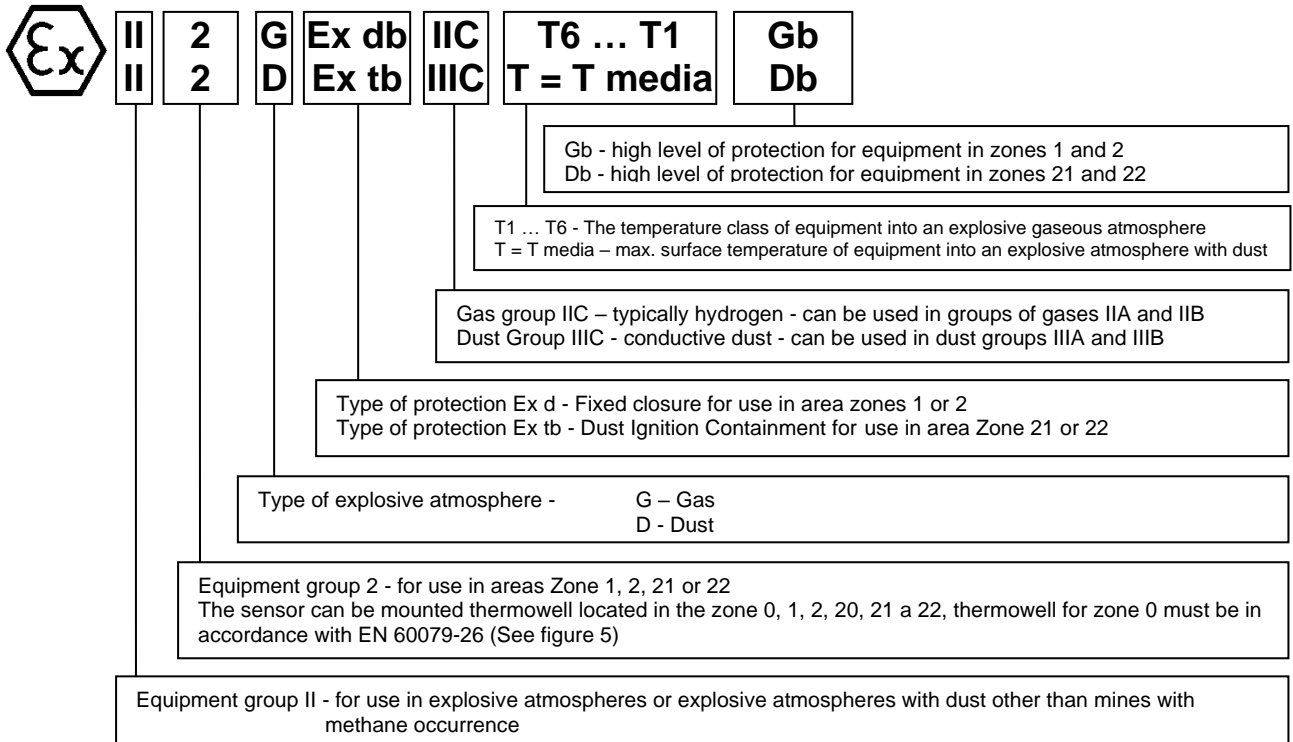
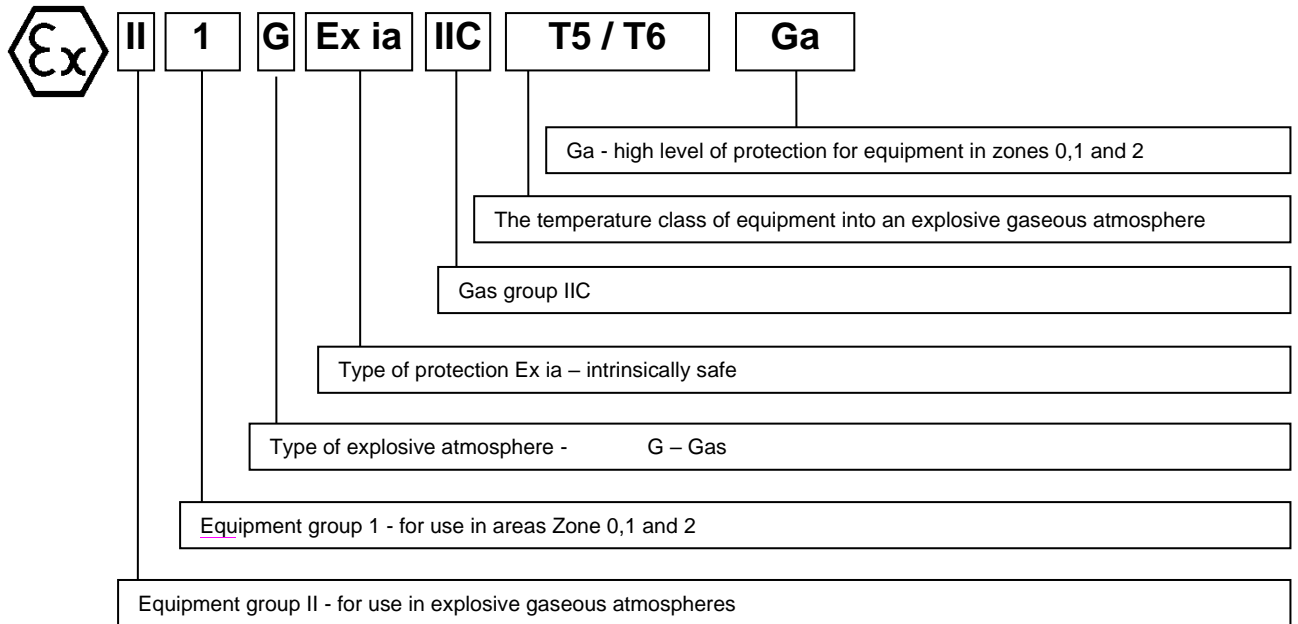

FIGURE 7 - INTRINSICALLY SAFE MARKING



May 2024

© ZPA Nová Paka, a.s.

