





The casing of the measuring insert is not separated from the inner intrinsically safe circuit according to the standard EN 60079-11. This information must be taken into account during installation.

#### Intrinsically safe version with converter:

according to built-in converter

#### Electric strength pursuant to EN 61010-1, Article 6.8.3:

500 V eff (only measuring insert without converter or design with insulated converter)

#### Electric insulation resistance pursuant to EN 61515, Article 5.3.2.4:

min. 1000 MΩ, at ambient temperature 20±15°C and max. 80% relative humidity, test voltage 500 V DC

#### Power supply of converter:

DC 24 V from source SELV, e.g. INAP 16 and INAP 901

#### Other data of converter:

refer to enclosed manual

#### Display:

LED display to loop 4-20mA

other date refer to enclosed manual

#### Ingress protection pursuant to EN 60529:

IP 68, 1 m, 30 min

#### Operation position:

discretionary; the gland shall not be situated upwards

#### Type of operation:

continuous

#### Sensor weight:

with adapter 135 mm 1.05 kg

#### Applied materials:

Thermowell	Steel 1.4541
Stem tube of measuring insert for thermocouple of type "J"	Steel 1.4541
for thermocouple of type "K"	INCONEL 600
Adapter	Steel 1.4541
Head	Aluminium alloy painted with polyester paint Steel 1.4401
Head terminals of terminal board	Brass with Ni surface
Connecting items of sensor	Stainless steel

## OPERATION CONDITIONS

The environment is defined by the group of parameters and their severity grades IE 36 pursuant to EN 60721-3-3 and the following operation conditions.

#### Ambient temperature for sensor head and gland according to the type of heads used:

- 50°C ≤ Ta ≤ 75°C for the heads of Al Alloy (XD- AD;XD-ADH)
- 50°C ≤ Ta ≤ 70°C for stainless steel heads (XD-SD)
- 40°C ≤ Ta ≤ 75°C for heads (XD-I80C; XD-I80Cwin)
- for design with converter (and display) pursuant to the type of converter (and display) (refer to the enclosed converter and display manual)

#### Maximum surface temperature of the sensor:

it complies with the maximum temperature of the measured medium

Maximum surface temperature for equipment operating in the environment with a threat of explosion of gases, steam and mist pursuant to EN 60079-0 and temperature class of the sensor are determined in dependency on the temperature of measured medium pursuant to the following table:

Temperature class	Maximum surface temperature	Maximum temperature of measured medium
T6	85°C	85°C
T5	100°C	100°C
T4	135°C	135°C
T3	200°C	200°C
T2	300°C	300°C
T1	450°C	450°C

For temperatures of the measured medium greater than the limit for temperature class T1, the maximum surface temperature Tx is determined from the maximum temperature of the measured Tm media and the safety addition of 10 ° C.

$T_x = T_m + 10 \text{ ° C}$ .

Maximum permitted surface temperature for the equipment operating in the environment with a threat of explosion of dust pursuant to EN 61241-14:

- a) Temperature limitation due to occurrence of stirred dust:

$$T_{\max} = 2/3 T_{ci}$$

where  $T_{ci}$  is the temperature of ignition of stirred dust

- b) Temperature limitation due to occurrence of layers of dust to 5mm thickness:  $T_{\max} = T_{5\text{mm}} - 75 \text{ °C}$

where  $T_{5\text{mm}}$  is the temperature of ignition of dust layer 5mm thick

- c) Dust layers over 5 mm – refer to EN 61241-14

Maximum permitted surface temperature is defined by the lower value of the values specified above.

Intrinsically safe measuring inserts can be used in intrinsically safe circuits of group II electrical equipment.



#### WARNING

The user shall guarantee that the maximum surface temperature of any part of the sensor does not exceed the temperatures of ignition of any gas, steam or dust, which can occur, due to external thermal effects.

#### Relative ambient humidity:

- 10 to 100 % with condensation, with upper limit of water content 29 g H<sub>2</sub>O/kg of dry air
- For design with converter pursuant to type of converter (refer to enclosed converter manual)
- For design with converter and display (refer to enclosed converter and display manual)

#### Vibrations:

Nominal length [mm]	100	160	250	400	630
Frequency range [Hz]	10 to 500				
Drift amplitude [mm]	0.2	0.2	0.15	0.15	0.15
Acceleration amplitude [ms <sup>-2</sup> ]	29.4	29.4	19.6	19.6	19.6

Atmospheric pressure: 70 to 106 kPa

#### Maximum speed of flow of liquids:

Maximum speed of flow [m/s]	Nominal length [mm]				
	100	160	250	400	630
Water steam and air	50	25	8	2.5	1
Water	5	3	3	1.5	0.2

## METROLOGICAL DATA

Sensing probe: measuring thermocouple J (Fe-CuNi) or K (NiCr-NiAl) pursuant to EN 60584-1, Ø 6 mm, tolerance class 2 or 1, single with insulated measuring end or double with independent measuring end

#### Output signal of

analogue converter (linear with thermoelectric voltage):  
4 to 20 mA

programmable converter (linear with measured temperature):  
4 to 20 mA (+ digital for HART protocol)

#### Calibration depth of immersion of the measuring insert of the sensor

for temperature points within the range from -70 to 250°C:  
200 mm (min. 160 mm)

for temperature points over 250°C:  
300 mm (min. 260 mm)

The distance of the flange of the measuring insert from the medium level in the calibration bath shall be at least 40 mm at temperatures up to 250°C and min. 70 mm at temperatures over 250°C.

Temperature response time pursuant to EN 60751 in whirling water (characteristic value):

$\tau_{0.5}$  29 s

$\tau_{0.9}$  95 s

## DESIGNATION :

#### Data on head label

- Trademark of the manufacturer
- Made in Czech Republic
- Type of thermoelectric sensor / tolerance class
- Measuring range or pre-set converter range
- Product ordering number
- Ingress protection
- Serial number
- Output signal 4 to 20 mA (design with converter)
- Ambient temperature
- Designation of non-:
  - II 1/2 G Ex db IIC T6...T1 Ga/Gb
  - II 1/2 D Ex ta/tb IIIC T=T media Da/Db
  - II 1 G Ex ia IIC T5/T6 Ga
- and number of EC Type Examination Certificate
- Designation of non-explosiveness and No. of EU Type Examination Certificate (for design with converter Ex i)
- CE mark 1026

**Data on measuring insert label**

- Trademark
- Type of sensor / tolerance class
- Serial number

**Data on converter label**

- Trademark
- Sensor type
- Pre-set temperature range
- Designation of non-explosiveness and EU-Type Examination Certificate number for design with converter Ex ia
- CE mark with identification number of the notified person (for design with converter Ex ia)

**Data on display**

- Trademark
- CE mark

**DELIVERY**

Unless agreed otherwise with the customer, each delivery includes

- Delivery note
- Sensor pursuant to the purchase order
- Sealing ring
  - o 21x27 TPD 62-014-91 for connecting thread G $\frac{1}{2}$  and M20x1,5
  - o Cu 27x32x1.5 (ČSN 02 9310.2) for connecting thread M27x2 and G $\frac{3}{4}$
  - o Cu 33 x 39 x 2 (ČSN 02 9310.2) for connecting thread G1
 (for thread  $\frac{3}{4}$ -14NPT, the sealing ring is not delivered)
- Allen key 1.5 mm
- Separately ordered accessories; pursuant to the catalogue of, type 991:
  - o Suitable thermowells and nipples
  - o Suitable cable gland. An instruction sheet is delivered with each cable gland
- Optional accessories to the sensor with programmable converter
  - o Configuration (parameterization) programme pursuant to the required converter
  - o Communication modem (for serial port RS 232C) pursuant to the required converter
- Accompanying technical documentation in Czech
  - o Product manual
  - o Product quality and completeness certificate, which also serves as the warranty certificate
  - o EU Declaration of Conformity

If it is established in the purchase contract or agreed otherwise, the following documentation can be also delivered with the product

- Copy of the Inspection Certificate 3.1 for material of thermowell with the heat number
- Calibration sheet (for uncertified calibrated design)
- Test report about the seismic and the vibration qualification
- EU Declaration of Conformity (for design with converter)
- Copy of EU-Type Examination Certificate pursuant to the Directive No 2014/34/EU for fixed closure and dust-tight closure
- Copy of EU-Type Examination Certificate pursuant to the Directive No 2014/34/EU for Ex ia design

**CERTIFICATION**

- Non-explosiveness Ex ia, EU-Type Examination Certificate pursuant to the Directive 2014/34/EU. FTZÚ 08 ATEX 0200X as amended
- Non-explosiveness Ex ia, EU-Type Examination Certificate pursuant to the Directive 2014/34/EU FTZÚ 21 ATEX 0007X
- Non-explosiveness Ex ia, EU-Type Examination Certificate pursuant to the 2014/34/EU (pursuant to the type of the converter and display)

**CALIBRATION**

It is realized pursuant to TPM 3342-94 and in compliance with EN 60584-1, usually in three temperature points spread evenly within the operation range of the sensor or in the points according to the requirement of the customer. Calibration sheets with measured data are issued for calibrated sensors.

**RELIABILITY**

Indicators of reliability in operation conditions and ambient conditions specified herein

- Medium time of operation between failures 96 000 hours (inf. value)
- Expected service life 10 years

**PACKING**

Both sensors and accessories are delivered in a packing ensuring resistance to the impact of thermal effects and mechanical effects pursuant to controlled packing regulations.

**TRANSPORT**

The sensors may be transported on conditions corresponding to the set of combinations of classes IE 21 pursuant to EN IEC 60721-3-2 (i.e. by airplanes and trucks, in premises that are ventilated and protected against atmospheric conditions).

**STORAGE**

The sensors may be stored on conditions corresponding to the set of combinations of classes IE 12 pursuant to EN IEC 60721-3-1 but with ambient temperature between -20 and 70 °C (i.e. in places where temperature and humidity are not controlled, with a threat of condensation, dripping water and formation of ice, without a special threat of an attack with biological agents, with vibrations of small significance and not situated close to sources of dust and sand.)

**ORDERING TEMPERATURE SENSORS**

The purchase order shall specify

- Name
- Product ordering number
- Ex ia design is ordered using codes JIX, or DUX according to table 1
- Additional requirements for sensor design pursuant to Table 2
- Request for other documentation pursuant to Table 2
- Measuring range
- If calibration is required and in what temperature points
- If the delivery of thermowell and nipple pursuant to the type 991 is required for the sensor as accessories
- If optional accessories to the sensor with programmable converter is required
- Request for other documentation according to Article DELIVERY
- Other (special) requirements
- Number of pieces

Behind the ordering number specified pursuant to Table 1, the customer shall identify the required range of measured temperature (i.e. so-called lower and upper temperature limits in °C) and, as the case may be, other non-standard required parameters for converter configuration (e.g. indication of sensor tripping, dampening, required designation - tagging etc.).

**EXAMPLE OF PURCHASE ORDER****Standard design:**

Thermoelectric temperature sensor Ex d (Ex t) with thermowell ČSN  
Without converter  
344 412 331 K2/JI/Q4  
Calibration points 250, 350 and 450°C  
Range -70 to 450°C  
6 pcs

**Special requirement:**

Thermoelectric temperature sensor Ex d (Ex t) with thermowell ČSN  
With converter  
344 912 311 J2/HCF  
Nominal length L 380 mm  
Range 0 to 300°C  
6 pcs

**ORDERING ACCESSORIES**

The purchase order shall specify:

- Name
- Ordering number
- Number of pieces

**EXAMPLE OF PURCHASE ORDER**

**Standard design:**

1. Nipple  
991 NVP4 M27 72  
6 pcs
2. Cable gland  
991 VM 612  
5 pcs

**Special request:**

Nipple  
991 NVP4 M27 99  
material 1.5415  
6 pcs

**TABLE 1 - DESIGN OF TEMPERATURE SENSORS Ex d (Ex t, Ex i) TO THERMOWELL DIN TYPE 344**

SPECIFICATIONS					OBJEDNACÍ ČÍSLO															
					344	x	x	x	x	x	x	x	x	x	/xxxxxx	/xxx				
Nominal length L [mm]	100	Length of adapter L <sub>n</sub> [mm]	135	Length of measuring insert L <sub>mv</sub> [mm]	280	1														
	160				2															
	250				3															
	400				4															
	630				5															
	Other (min. 75) *)				9															
Nominal length L [mm]	100	Length of adapter L <sub>n</sub> [mm]	65	Length of measuring insert L <sub>mv</sub> [mm]	210	1														
	160				2															
	250				3															
	400				4															
	630				5															
	Other (min. 75) *)				9															
Length of adapter L <sub>n</sub> [mm]	135					1														
	65 maximal measuring range [°C] -200 to 250					2														
	Other (min. 47) *) **)					9														
Thermowell material	1.4571 ****) maximal measuring range [°C] -200 to 400						1													
	1.4541 ****) maximal measuring range [°C] -200 to 600						2													
	Other *) ***)						9													
Connecting thread	G1/2							1												
	G1							2												
	M27x2							3												
	G3/4							4												
	3/4-14 NPT							5												
	M20x1,5							6												
	Other *)							9												
Head of the sensor with thread for gland Ex d (Ex t) - overview of glands see Tab.4	Aluminium alloy painted with blue epoxy colour	M20x1.5											1							
		1/2-14NPT											2							
	Corrosion resistant steel 1.4401	M20x1.5											3							
		1/2-14NPT											4							
Tube of measuring insert for sensor with thermowell (Ø6 ± 0,1 mm)																	1			
Thermocouple	K																	K		
	J																	J		
Accuracy class	1 *)																	1		
	2																	2		
Design of measuring ends of thermocouple pursuant to Figure 1	Single thermocouple, insulated end																	/JI		
	Double thermocouple, independent end																	/DU		
	Single thermocouple, insulated end	only for TC "K" a "J", with measuring insert ø 6, length of measuring insert L <sub>mv</sub> 100 – 3025 [mm]																/JIX		
	Double thermocouple, independent end																	/DUX		

**TABLE 1 - DESIGN OF TEMPERATURE SENSORS Ex d (Ex t, Ex i) TO THERMOWELL DIN TYPE 344 (continuation)**

SPECIFICATIONS						OBJEDNACÍ ČÍSLO													
						344	x	x	x	x	x	x	x	x	x	x	/xxxxxx	/xxx	
Converter (design of thermocouple measuring ends: single thermocouple, isolated end)	Programmable linear output signal with temperature	TH 200	•														/TH200		
		TH 200-ex	•	•														/TH200X	
		MINIPAQ-HLP																/MINIPAQ	
		APAQ C130																/C130	
		IPAQ C202																/C202	
		IPAQ C330	•		•													/C330	
	Programmable with HART protocol linear output signal with temperature	IPAQ C330X	•	•	•													/C330X	
		IPAQ C520	•															/C520	
		IPAQ C520S *****)	•															/C520S	
		IPAQ C520X	•	•														/C520X	
		IPAQ C520XS *****)	•	•														/C520XS	
		IPAQ C530	•		•													/C530	
		IPAQ C530X	•	•	•													/C530X	
		TH 300	•															/TH300	
		TH 300-ex	•	•														/TH300X	
		248 HA NA	•															/248HANA	
	Other *)	248 HA I1	•	•														/248HA11X	
		644 HA NA	•															/644HANA	
		644 HA I1	•	•														/644HA11X	
	Without converter (for converter installation by the customer)																/99		
LED display to loop 4-20 mA (not possible with head from corrosion resistant steel) (only with converter INPAL 420, APAQ-HRF, TH 100, MINIPAQ-HLP)						LPI-02											/LD		

**Standard design**

- \*) Only as a special requirement after an agreement with the manufacturer
- \*\*) In case of adapter length below 135 mm (minimum 65 mm), the temperature range is decreased to -70 to 250 °C
- \*\*\*) For Zone 0, a thermowell from corrosion-resistant alloy shall be used (pursuant to EN 60079-26)
- \*\*\*\*) Thermowells of these materials are suitable for contact with food
- \*\*\*\*\*) Functional safety SIL2

**TABLE 2 – ADDITIONAL REQUIREMENT FOR DESIGN OF TEMPERATURE SENSORS, TYPE 344**

SPECIFICATIONS			CODE	
CALIBRATION	NUMBER OF CALIBRATION POINTS	CALIBRATION RANGE		
Calibration by TPM 3342-94, define calibration points	3	0 to 800 °C	/Q4	
	3	0 to 1100 °C	/Q42	
	Other	0 to 1100 °C	/Q9	
REQUIREMENT FOR OTHER DOCUMENTATION		USE		
EU Declaration of Conformity		for design with converter		/EU
Copy of EU-Type Examination Certificate acc to the 2014/34/EU (ATEX)		for Ex ia design		/Exi
Copy of the Inspection Certificate 3.1 acc to EN 10204 for material of tube with the heat number				/3.1
Declaration of Conformity with purchase order 2.1 pursuant to EN 10204				/2.1

Specify the code behind ordering number. Define calibration points for codes Q4, Q42 a Q9.

**TABLE 3 – ACCESSORIES - OVERVIEW OF DESIGNS RECOMMENDED NIPPLES, TYPE 991 (order separately)**

SPECIFICATION						ORDERING NUMBER												
						991	xxx	x	xxx	xx								
Shape	Direct nipple						NVP											
	Oblique (chamfer 45°)						NVS											
Internal bore	M20×1,5	for embed sealing ring	PN	40														
	G 1/2																	
	M20×1,5	without embed for sealing ring									160							
	G 1/2																	
	M27×2																	
	G 3/4																	
	3/4 – 14 NPT																	
	G1																	
Other *)																		
Material	1.0308 or 1.0122	surface treatment	preservation with grease – oil	maximum operation temperature [°C]	300 (only PN 40)						M20	13						
	1.0577										G12							
											M27							
											G34							
											N34							
15 128.5/ 14MoV6-3	-			400						G01	15							
1.4541										M27								
										G34								
Other *)	pursuant to material			550						N34	51							
												72						
												99						

\*) upon a special requirement after an agreement with the manufacturer

TABLE 4 - OVERVIEW OF DESIGNS AND ORDERING OF CABLE GLANDS Ex d (Ex t) BRASS – TYPE 991

SPECIFICATION							Ordering number			
							991	xx	xxx	
Gland Ex d (Ex t) brass		Cable clamp (clamping module)			Thread	Torque of gland body	For cable Ø [mm]			
Size	Wrench		Size	Dimension						
	A	B		C	Ds					
No. 4	OK 17	OK 24	No. 4	5	20	M20x1.5	30 - 35 Nm	4,5-8.5	VM	458
No. 5	OK 19		No. 5	5	22			7-11	VM	711
No. 6	OK 24		No. 6	6	27.5			10-16	VM	016
No. 4	OK 17		1/2-14 NPT	No. 4	5	20	25 - 30 Nm	4,5-8.5	VK	458
No. 5	OK 19			No. 5	5	22		7-11	VK	711
No. 6	OK 24			No. 6	6	27.5		10-15.5	VK	015

TABLE 5 –OVERVIEW OF SEALING RINGS TYPE 991 SUPPLIED TO TEMPERATURE SENSORS

EXTERNAL FIXING THREAD OF TEMPERATURE SENSORS	SEALING RING			
	DIMENSION [mm] Ød x ØD x t	MATERIAL	NUMBER	ORDERING NUMBER
M20x1,5	21x27x2	copper thermally insulating insert	1 Pcs	991 TK 21
G1/2				
M27x2	27x32x1,5	copper		991 TK 27
G3/4				
G1	33x39x2			991 TK 33
3/4-14 NPT	-	-	-	-

The sealing ring is supplied to each sensor by default, only for the sensor with internal thread 1/2-14NPT the sealing ring is not supplied. The sealing ring can also be ordered separately using ordering number

## INSTALLATION AND CONNECTION

### SENSOR INSTALLATION

Install the sensors by screwing into the nipple on the piping (technological equipment). Before the installation, put on the enclosed sealing ring in advance (for thread 3/4-14NPT, the sealing ring is not used). During the installation torque of 70 Nm is recommended for thread M20 x 1,5, G 1/2 and 3/4-14NPT and torque of 150 Nm it is recommended for thread M27 x 2 a G3/4.

A proposal of securing the thermowell of the temperature sensors Ex d for nominal lengths exceeding 630 m is in Figure 2; examples of installation of direct and oblique nipples are in Figure 8.

With respect to maintaining metrological properties and the longest possible service life, it is not recommended to install the sensors in places with high turbulence of the medium, which is caused e.g. by a rapid transition from a small diameter of the piping to a larger one (when failing to comply with the required shape and dimensions of diffuser behind the flow meter), etc. Recommended distance of the temperature sensor from the installation flange of the flow meter is min. 1 m.



#### WARNING

The temperature sensor may be install to the thermowell located in the zone 0 (20), zone 1 (1) or zone 2 (22).

The other parts of the sensor (fitting, adapter, connecting head) may be located in zone 1 (21) or zone 2 (22).

When installing sensor in the thermowell located in zone 20, a pre-fuse with the following parameters must be used in the converter encoder circuit: Ceramic, quick break (F), short circuit resistance 1500A (H), e.g. ceramic tube fuse Ø5 x 20 mm, F100mA.

Distance of the fixed closure Ex d IIC from close structures or between the closures shall be at least 40 mm.

The temperature sensor with a paint finish must be installed in an explosive atmosphere with dust so as to avoid the occurrence of creep discharges

### INSTALLATION OF CABLE GLAND

To secure the fixed and dust-tight closure, only the certified cable gland Ex d IIC (Ex tb IIC) with Ingress protection IP 68 shall be used (refer to accessories 991 or another similar gland). It shall be tightened in the sensor head in the prescribed way.

Torque of gland body:

- a) for gland with thread 1/2 - 14NPT 25 – 30Nm
- b) for gland with thread M20x1.5 30 – 35Nm

Installation of the cable in the gland, its sealing and securing against pull-out shall be realized pursuant to the instruction sheet of the gland supplier.



#### WARNING

Do not use other sealing rings in the gland than the original ones delivered by the manufacturer. Do not change artificially the outer diameter of the cable e.g. by winding it around with electrical insulating tapes.

### ELECTRICAL CONNECTION

The electrical connection may be only realized by qualified workers.

The sensor installation in conditions with explosive gaseous atmosphere or flammable dust shall comply with the requirements of EN 60079-14.

The terminal board of the sensor (converter) is accessible after unscrewing the lid of the head.

Connect the evaluation devices to the sensor with a cable with double insulation; internal wires with Cu core (sensor with converter) or compensation wiring (sensor without converter) 0.5 to 1.5 mm<sup>2</sup>. Sensors without converter connect with unarmoured shielded compensation or double insulated thermocouple wiring with cross section 0.5 to 1.5 mm<sup>2</sup> and outer diameter according to cable gland.

Seal the cable in the gland by prescribed tightening of the closing nut pursuant to instruction sheet of the gland Then secure it with clamp against pull-out.



#### WARNING

The connecting cable must have a casing of thermoplastic, thermoset or elastomeric materials. The cable must be circular and compact, the filler or shell must be extruded and the filler material, if used, must be non-absorbent. The length of the connecting cable must be at least min. 3 m. Temperature resistance of the cable shall comply with the ambient temperature!

The cable insulation shall have chemical and mechanical resistances in compliance with the conditions, in which the cable will be installed. It is recommended supporting the cable along its length between the sensor and the follow-up device. In the environment with interfering signals, use shielded cable in the power supply circuit. Shielding may be only grounded (earthed) in one point. The cable should not be placed together with power cables.

In case of the sensor with HART protocol converter, the maximum length of wiring is defined by the arrangement of wires of the connecting cable. The total length of wiring may be up to 1500 m. It requires a twisted two-wire with shared shielding with the diameter of the cross section min. 0.5 mm<sup>2</sup>. The HART communicator is connected to the supply loop of the sensor with converter pursuant to Figure 4.

To achieve reliable communication, the total load resistance of min. 250 Ω shall be in the circuit of the output loop.

**WARNING**   
**Programmable converter may not be connected to a computer or a HART communicator if the converter is located in explosive environment.**

The surface temperature of the converter must not exceed the maximum surface temperature for a given temperature class.

For installation in a dangerous area, a connection is required (placing on the same potential). You can use the terminals on the sensor head to do this.

The sensor need not be connected separately to the interconnection system if it is firmly attached and metallically connected to the components or piping that is connected to the interconnection system.

**Maximum cross-section of wire for connection to external and internal terminals:**

Internal terminal: stranded wire 1.5 mm<sup>2</sup>, full wire 2.5 mm<sup>2</sup>  
 External terminal: stranded wire 4.0 mm<sup>2</sup>, full wire 6.0 mm<sup>2</sup>  
 If stranded wires are used for the interconnection, they shall be protected against fraying with pressing hollow.

**SENSOR HEAD WITH TERMINALS**

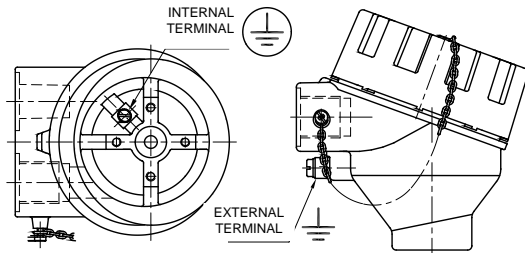

**CLOSING HEAD OF FIXED CLOSURE Ex d**

After electrical connection of the sensor, the lid of the head shall be fully tightened by hand, then released slightly to ensure matching with the closest groove against the securing screw and fixed by this screw against releasing. If the lid of the sensor is not tightened and secured by the above mentioned screw, the sensor does not comply with the requirements of fixed closure Ex d.

**WARNING:**   
**Power supply of the sensor may not be connected before closing the fixed closure!**

**SENSOR INSTALLATION WITHOUT CONVERTER AND SENSOR WITH CONVERTER Ex ia TO ZONE 0 (20)**

**WARNING:**   
**The user is responsible for ensuring that during operation in zone 0 is between the sensor head from an aluminium alloy and other equipment preclude any risk of ignition due to impact and friction.**

**The sensor without converter** can be used as a simple device pursuant to EN 60079-11 Article 5.7 in an intrinsically safe circuit Ex ia pursuant to EN 60079-25. For a simple device, the maximum temperature can be determined from the value of the P<sub>0</sub> of the connecting device and the temperature class is determined.

**The sensor with converter Ex ia** may be used in case of compliance with the parameters Ex ia of the converter according to the enclosed converter manual.

In intrinsically safe circuits, only insulated cables that are capable of withstanding an electrical strength test with a voltage equal to twice the voltage in the intrinsically safe circuit or 500 V eff (DC 750 V) must be used, with a larger value being taken.

In case of installation of intrinsically safe circuits, including cables, the maximum permitted inductance, capacity or ratio LiR and surface temperature may not be exceeded. Permitted values can be found out in the documentation of the follow-up equipment or label with the designation. Locate the follow-up equipment outside of the dangerous area. An intrinsically safe source must be always used that is approved for power supply of intrinsically safe equipment in the sense of EN 60079-11.

Shielding of the cable of the intrinsically safe circuit must be grounded in the same place as the intrinsically safe circuit, the connection must be outside the dangerous area  
 If the intrinsically safe circuit is isolated from the ground, the shield must be connected in one place to the protective interconnection system. This can be using the terminals on the sensor head.

**COMMISSIONING**

After the installation of the sensor, including closing the fixed closure and connection of the follow-up (evaluation) device to the supply voltage (and the settlement period of the converter), the equipment is prepared for operation.

**WARNING**   
**After installation must be require initial inspection equipment and installations according to EN 60079-17.**

**OPERATION AND MAINTENANCE**

The sensor does not require any operation, maintenance and follow-up periodical revisions or permanent supervision of expert staff shall be carried out pursuant to EN 60079-17.

**WARNING**   
**Any intervention into the sensor and its structure will result in a change of properties and can result in an explosion!**

**SENSOR UNINSTALLATION**

**WARNING**   
**Warning: Temperature sensor is in design Ex and must be disconnected from the power supply source before opening the lid of the head and releasing the cable gland in the explosive environment!**

Release the securing screw of the lid with ALLEN key 1.5 mm (a part of accessories). The terminal board of the sensor (converter) is accessible after unscrewing the lid of the head. Measuring insert of the sensor can be replaced and is uninstalled from the head after disconnecting the cable by releasing two screws.

Before a complete uninstallation of the sensor, the wire for mutual interconnection shall be released from the external terminal on the sensor.

Disconnect the connecting cable from the terminal board, then release it from the clamp on the outlet and from closing nut of the outlet. Unscrew the sensor from the thermowell; torque for releasing is approx. 70 Nm. While releasing the screw-joint of the sensor, the thermowell may never be released.

**SPARE PARTS**

Spare parts shall be delivered by the manufacturer. Relevant measuring inserts can be ordered pursuant to the following table:

SPECIFICATIONS	ORDERING NUMBER					
	MV340	/xxx/	x	x	/xxx x	
Length of measuring insert [mm]		Pursuant to tab. 1				
Tube of measuring insert [mm]	6 ± 0,1		1			
	∅ 8mm (with limiting bush)		2			
	3 ± 0,1		3			
Sensing probe	Thermocouple K			K		
	Thermocouple J			J		
Accuracy class	1				1	
	2				2	
Connection of the terminal board and design of measuring ends of thermo-couple or converter	Single thermocouple, insulated end				/JI	
					/JIX*)	
	Double thermocouple, independent end					/DU
						/DUX*)
Converter pursuant to tab. 1					/converter	

\*) Ex ia design (only with measuring insert ∅ 6, length of measuring insert L<sub>mv</sub> 100 – 3025 [mm])

**EXAMPLE OF PURCHASE ORDER OF MEASURING INSERT**

Thermoelectric measuring insert without converter  
 340 /430 1K2/JI  
 6 pcs

To order the certified measuring inserts, specify the code according to Table 2 – Additional requirements – behind the ordering number.

The measuring inserts are marked according to Article DESIGNATION. Designation is completed with the ordering number.

Each delivery includes

- Delivery note
- Measuring insert pursuant to the purchase order
- Optional accessories to the measuring insert with a programmable converter
  - o Configuration program according to the required converter
  - o Communication modem (for serial port RS 232C) according to the required converter
- Accompanying technical documentation in Czech
  - o Product manual
  - o Product quality and completeness certificate, which also serves as the warranty certificate
  - o EU Declaration of Conformity (for Ex ia design)

If it is established in the purchase contract or agreed otherwise, the following documentation can be also delivered with the product

- Calibration sheet (for calibrated design)
- EU Declaration of Conformity (for design with converter)
- Copy of EU-Type Examination Certificate pursuant to the Directive No 2014/34/EU for Ex ia design

**WARRANTY**

The warranty period is 24 months from the receiving of the product by the customer, unless established otherwise in the contract. Rejection of defects shall be enforced in writing at the manufacturer within the warranty period. The rejecting side shall identify the product name, ordering and manufacturing numbers, date of issue and number of the delivery note, clear description of the occurring defect and the subject of the claim. If the rejecting side is invited to send the device for repair, it shall do so in the original package of the manufacturer and/or in another package ensuring safe transport.

The warranty shall not apply to defects caused by unauthorized intervention into the device, its forced mechanical damage or failure to comply with operation conditions of the product and the product manual.

**REPAIRS**

The sensors shall be repaired by the manufacturer. They shall be sent for repair in the original or equal package without accessories.

**DISABLING AND LIQUIDATION**

The product and its package do not include any parts that could impact the environment.

Products that are withdrawn from operation, including their packages (with the exception of products marked as electrical equipment for the purposes of return withdrawal and separate salvage of electrical waste), may be disposed of to sorted or unsorted waste pursuant to the type of waste.

The manufacturer realizes free return withdrawal of marked electrical equipment (from 13.8.2005) from the consumer and points out the danger connected with their illegal disposal. The package of the sensor can be recycled completely. Metal parts of the products are recycled, non-recyclable plastic materials and electrical waste shall be disposed of in accordance with applicable legislation.

**FIGURE 1 - DESIGN OF MEASURING ENDS OF JACKETED THERMOCOUPLES (SCHEMATIC ILLUSTRATION)**

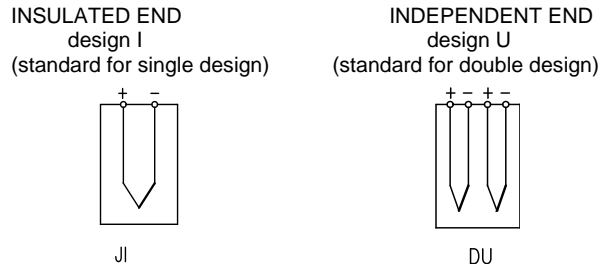

**FIGURE 2 - PROPOSAL OF SECURING THERMOWELL OF TEMPERATURE SENSORS**

(for nominal lengths exceeding 630 mm)  
 Prescribed thermowells of type 991 (pursuant to ON 02 7210, ON 02 7212, ON 02 7215 or ON 02 7217) shall be used.

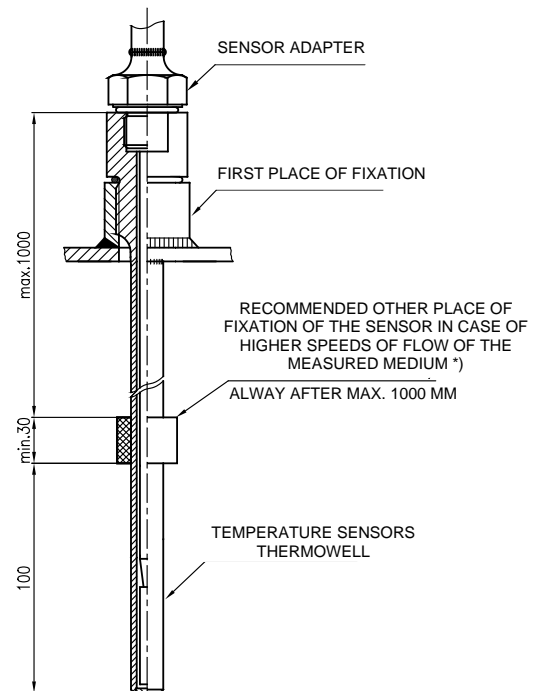

\*) In case of flow of the measured medium, the thermowells are stressed with dynamic effects of the flowing medium and this stress depends on the speed of flow, physical properties of the measured medium and immersion length of the thermowell. If the occurrence of such dynamic effects can be expected, it is recommended to realize further fixation of the sensor thermowell pursuant to the above mentioned proposal.



**FIGURE 3 - SCHEME OF CONNECTION OF TEMPERATURE SENSORS**

**SCHEME OF CONNECTION WITHOUT CONVERTER**

with single thermocouple

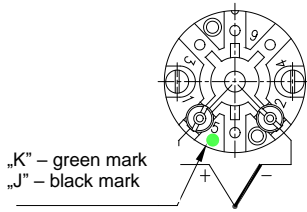

with double thermocouple

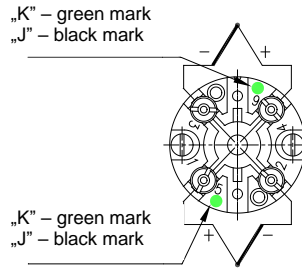

**SCHEME OF CONNECTION WITH CONVERTER AND DISPLAY**

with converter

with converter with HART protocol

with converter Ex ia

with converter Ex ia with HART protocol

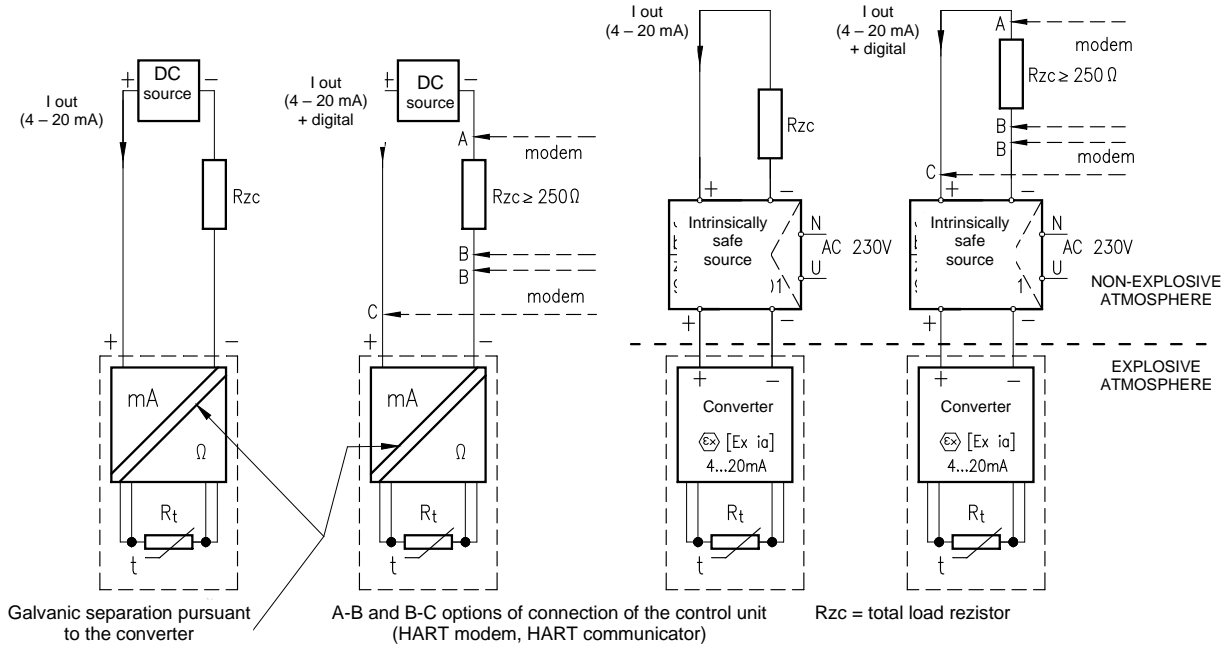

**FIGURE 4 - EXAMPLE OF OPERATION CONNECTION OF TEMPERATURE SENSOR WITH CONVERTER IN LOOP 4 - 20 mA**

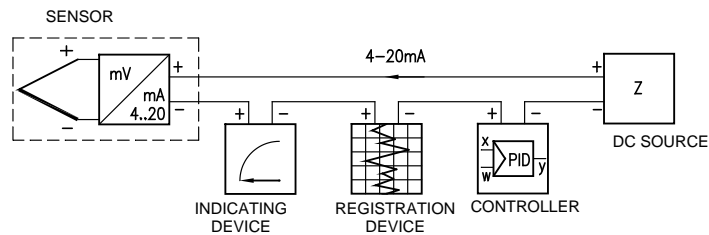

FIGURE 5 – MARK OF NON-EXPLOSIVENESS

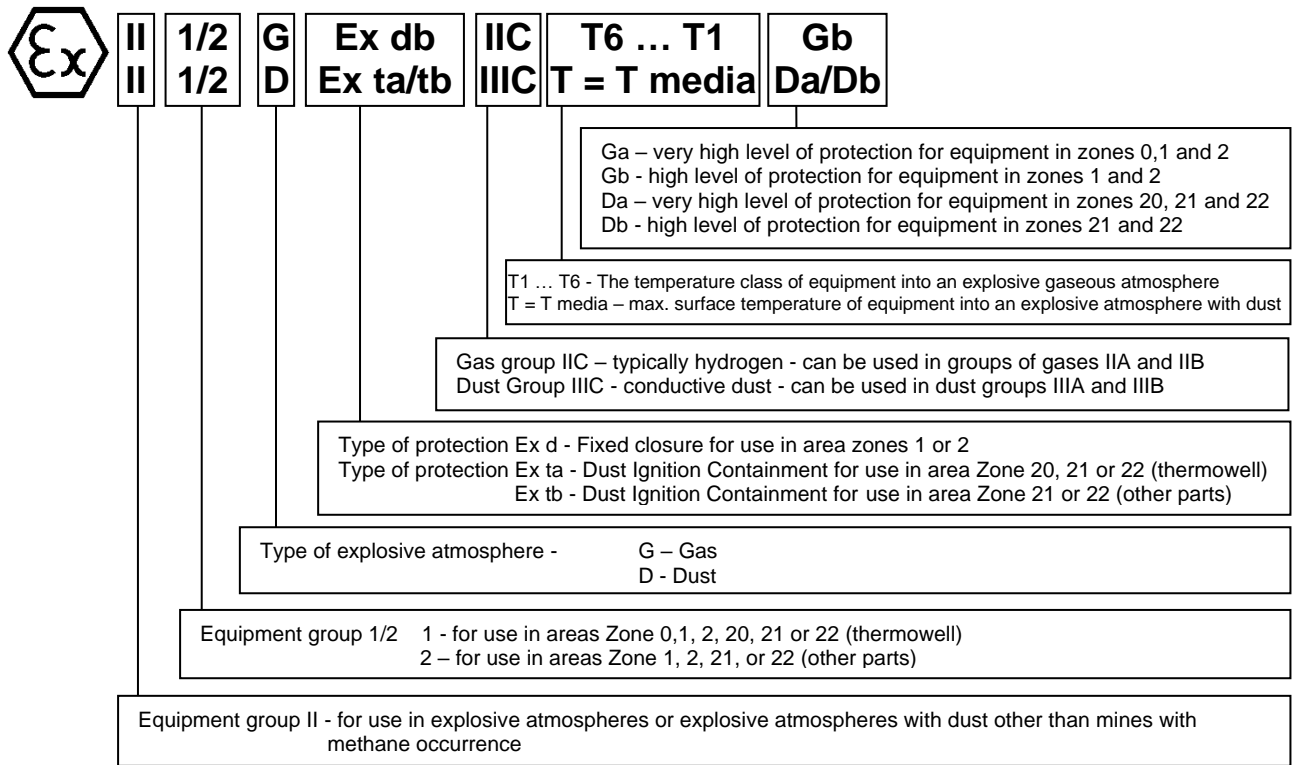
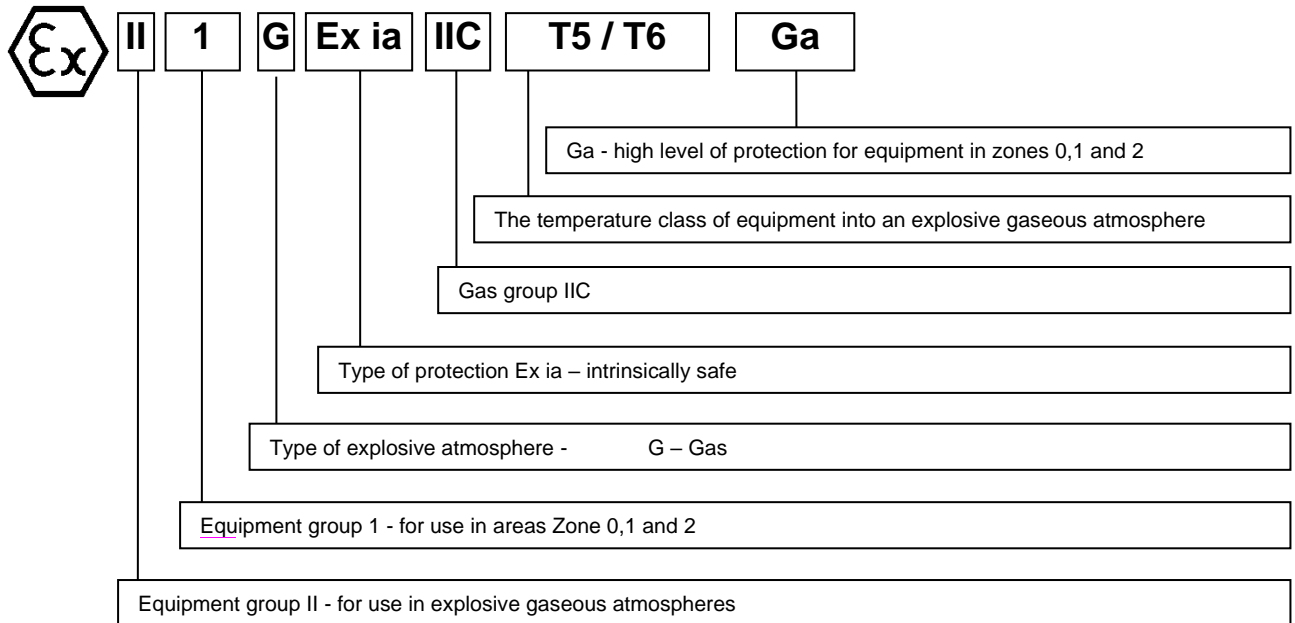
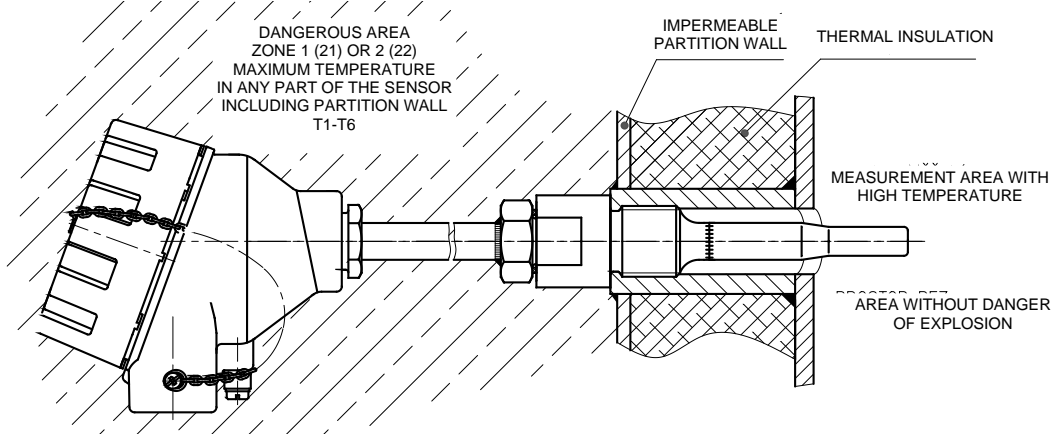

FIGURE 6 - INTRINSICALLY SAFE MARKING



**FIGURE 7 – EXAMPLE OF INSTALLATION OF TEMPERATURE SENSORS Ex d TO THERMOWELL ČSN**  
 (in case a higher limit of the measurement range is required on a level exceeding the required temperature class)



**FIGURE 8 - EXAMPLES OF THE INSTALLATION OF DIRECT AND OBLIQUE NIPPLES**

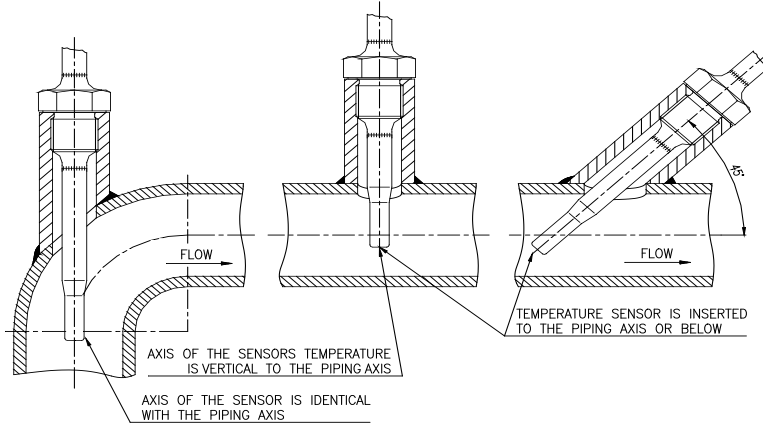

**WARNING**

- When using the sensor with an oblique nipple, locate the sensor with thermowell at an angle against the direction of flow.
- The sensor may not touch the opposite side of the piping.
- It is also advantageous to use the temperature sensors in the piping elbow. In such a case, locate the sensor with the thermowell against the direction of flow so that the measured medium flows around evenly

May 2024

© ZPA Nová Paka, a.s.

